

**KEITHLEY**

# S46 Microwave Switch System

## Instruction Manual

A GREATER MEASURE OF CONFIDENCE

# WARRANTY

Keithley Instruments, Inc. warrants this product to be free from defects in material and workmanship for a period of 1 year from date of shipment.

Keithley Instruments, Inc. warrants the following items for 90 days from the date of shipment: probes, cables, rechargeable batteries, diskettes, and documentation.

During the warranty period, we will, at our option, either repair or replace any product that proves to be defective.

To exercise this warranty, write or call your local Keithley representative, or contact Keithley headquarters in Cleveland, Ohio. You will be given prompt assistance and return instructions. Send the product, transportation prepaid, to the indicated service facility. Repairs will be made and the product returned, transportation prepaid. Repaired or replaced products are warranted for the balance of the original warranty period, or at least 90 days.

## LIMITATION OF WARRANTY

This warranty does not apply to defects resulting from product modification without Keithley's express written consent, or misuse of any product or part. This warranty also does not apply to fuses, software, non-rechargeable batteries, damage from battery leakage, or problems arising from normal wear or failure to follow instructions.

**THIS WARRANTY IS IN LIEU OF ALL OTHER WARRANTIES, EXPRESSED OR IMPLIED, INCLUDING ANY IMPLIED WARRANTY OF MERCHANTABILITY OR FITNESS FOR A PARTICULAR USE. THE REMEDIES PROVIDED HEREIN ARE BUYER'S SOLE AND EXCLUSIVE REMEDIES.**

**NEITHER KEITHLEY INSTRUMENTS, INC. NOR ANY OF ITS EMPLOYEES SHALL BE LIABLE FOR ANY DIRECT, INDIRECT, SPECIAL, INCIDENTAL OR CONSEQUENTIAL DAMAGES ARISING OUT OF THE USE OF ITS INSTRUMENTS AND SOFTWARE EVEN IF KEITHLEY INSTRUMENTS, INC., HAS BEEN ADVISED IN ADVANCE OF THE POSSIBILITY OF SUCH DAMAGES. SUCH EXCLUDED DAMAGES SHALL INCLUDE, BUT ARE NOT LIMITED TO: COSTS OF REMOVAL AND INSTALLATION, LOSSES SUSTAINED AS THE RESULT OF INJURY TO ANY PERSON, OR DAMAGE TO PROPERTY.**

## KEITHLEY

Keithley Instruments, Inc.

28775 Aurora Road • Cleveland, Ohio 44139 • 440-248-0400 • Fax: 440-248-6168  
1-888-KEITHLEY (534-8453) • [www.keithley.com](http://www.keithley.com)

Sales Offices: BELGIUM:

Bergensesteenweg 709 • B-1600 Sint-Pieters-Leeuw • 02-363 00 40 • Fax: 02-363 00 64

CHINA:

Yuan Chen Xin Building, Room 705 • 12 Yumin Road, Dewai, Madian • Beijing 100029 • 8610-82251886 • Fax: 8610-82251892

FINLAND:

Halsuantie 2 • 00420 Helsinki, Finland • 09-53 06 65 60 • Fax: 09-53 06 65 65

FRANCE:

3, allée des Garays • 91127 Palaiseau Cédex • 01-64 53 20 20 • Fax: 01-60 11 77 26

GERMANY:

Landsberger Strasse 65 • 82110 Germering • 089-84 93 07-40 • Fax: 089-84 93 07-34

GREAT BRITAIN:

Unit 2 Commerce Park, Brunel Road • Theale, Berkshire RG7 4AB • 0118 -929 75 00 • Fax: 0118- 929 75 19

INDIA:

1/5, Eagles Street • Langford Town • Bangalore 560 025 • 080 212 80-27 • Fax: 080 212 80 05

ITALY:

Viale San Gimignano, 38 • 20146 Milano • 02-48 39 16 01 • Fax: 02-48 30 22 74

JAPAN:

New Pier Takeshiba North Tower 13F • 11-1, Kaigan 1-chome • Minato-ku, Tokyo 105-0022 • 81-3-5733-7555 • Fax: 81-3-5733-7556

KOREA:

2FL., URI Building • 2-14 Yangjae-Dong • Seocho-Gu, Seoul 137-888 • 82-2-574-7778 • Fax: 82-2-574-7838

NETHERLANDS:

Postbus 559 • 4200 AN Gorinchem • 0183-63 53 33 • Fax: 0183-63 08 21

SWEDEN:

c/o Regus Business Centre • Frosundaviks Allé 15, 4tr • 16970 Solna • 08-50 90 46 00 • Fax: 08-655 26 10

TAIWAN:

13F-3, NO. 6, Lane 99, Pu-Ding Road, Hsinchu, Taiwan, ROC. • 886-3-572-9077 • Fax: 886-3-572-9031

---

# S46 Microwave Switch System Instruction Manual

©2001, Keithley Instruments, Inc.  
All rights reserved.  
Cleveland, Ohio, U.S.A.  
Second Printing, May 2003  
Document Number: S46-901-01 Rev. B

---

# Manual Print History

The print history shown below lists the printing dates of all Revisions and Addenda created for this manual. The Revision Level letter increases alphabetically as the manual undergoes subsequent updates. Addenda, which are released between Revisions, contain important change information that the user should incorporate immediately into the manual. Addenda are numbered sequentially. When a new Revision is created, all Addenda associated with the previous Revision of the manual are incorporated into the new Revision of the manual. Each new Revision includes a revised copy of this print history page.

Revision A (Document Number S46-901-01) ..... March 2001  
Revision B (Document Number S46-901-01) ..... May 2003

The following safety precautions should be observed before using this product and any associated instrumentation. Although some instruments and accessories would normally be used with non-hazardous voltages, there are situations where hazardous conditions may be present.

This product is intended for use by qualified personnel who recognize shock hazards and are familiar with the safety precautions required to avoid possible injury. Read and follow all installation, operation, and maintenance information carefully before using the product. Refer to the manual for complete product specifications.

If the product is used in a manner not specified, the protection provided by the product may be impaired.

The types of product users are:

**Responsible body** is the individual or group responsible for the use and maintenance of equipment, for ensuring that the equipment is operated within its specifications and operating limits, and for ensuring that operators are adequately trained.

**Operators** use the product for its intended function. They must be trained in electrical safety procedures and proper use of the instrument. They must be protected from electric shock and contact with hazardous live circuits.

**Maintenance personnel** perform routine procedures on the product to keep it operating properly, for example, setting the line voltage or replacing consumable materials. Maintenance procedures are described in the manual. The procedures explicitly state if the operator may perform them. Otherwise, they should be performed only by service personnel.

**Service personnel** are trained to work on live circuits, and perform safe installations and repairs of products. Only properly trained service personnel may perform installation and service procedures.

Keithley products are designed for use with electrical signals that are rated Measurement Category I and Measurement Category II, as described in the International Electrotechnical Commission (IEC) Standard IEC 60664. Most measurement, control, and data I/O signals are Measurement Category I and must not be directly connected to mains voltage or to voltage sources with high transient over-voltages. Measurement Category II connections require protection for high transient over-voltages often associated with local AC mains connections. Assume all measurement, control, and data I/O connections are for connection to Category I sources unless otherwise marked or described in the Manual.

Exercise extreme caution when a shock hazard is present. Lethal voltage may be present on cable connector jacks or test fixtures. The American National Standards Institute (ANSI) states that a shock hazard exists when voltage levels greater than 30V RMS, 42.4V peak, or 60VDC are present. **A good safety practice is to expect that hazardous voltage is present in any unknown circuit before measuring.**

Operators of this product must be protected from electric shock at all times. The responsible body must ensure that operators are prevented access and/or insulated from every connection point. In some cases, connections must be exposed to potential human contact. Product operators in these circumstances must be trained to protect themselves from the risk of electric shock. If the circuit is capable of operating at or above 1000 volts, **no conductive part of the circuit may be exposed.**

Do not connect switching cards directly to unlimited power circuits. They are intended to be used with impedance limited sources. NEVER connect switching cards directly to AC mains. When connecting sources to switching cards, install protective devices to limit fault current and voltage to the card.

Before operating an instrument, make sure the line cord is connected to a properly grounded power receptacle. Inspect the connecting cables, test leads, and jumpers for possible wear, cracks, or breaks before each use.

When installing equipment where access to the main power cord is restricted, such as rack mounting, a separate main input power disconnect device must be provided, in close proximity to the equipment and within easy reach of the operator.

For maximum safety, do not touch the product, test cables, or any other instruments while power is applied to the circuit under test. ALWAYS remove power from the entire test system and discharge any capacitors before: connecting or disconnecting

cables or jumpers, installing or removing switching cards, or making internal changes, such as installing or removing jumpers. Do not touch any object that could provide a current path to the common side of the circuit under test or power line (earth) ground. Always make measurements with dry hands while standing on a dry, insulated surface capable of withstanding the voltage being measured.

The instrument and accessories must be used in accordance with its specifications and operating instructions or the safety of the equipment may be impaired.

Do not exceed the maximum signal levels of the instruments and accessories, as defined in the specifications and operating information, and as shown on the instrument or test fixture panels, or switching card.

When fuses are used in a product, replace with same type and rating for continued protection against fire hazard.

Chassis connections must only be used as shield connections for measuring circuits, NOT as safety earth ground connections.

If you are using a test fixture, keep the lid closed while power is applied to the device under test. Safe operation requires the use of a lid interlock.

If a  screw is present, connect it to safety earth ground using the wire recommended in the user documentation.

The  symbol on an instrument indicates that the user should refer to the operating instructions located in the manual.

The  symbol on an instrument shows that it can source or measure 1000 volts or more, including the combined effect of normal and common mode voltages. Use standard safety precautions to avoid personal contact with these voltages.

The  symbol indicates a connection terminal to the equipment frame.

The **WARNING** heading in a manual explains dangers that might result in personal injury or death. Always read the associated information very carefully before performing the indicated procedure.

The **CAUTION** heading in a manual explains hazards that could damage the instrument. Such damage may invalidate the warranty.

Instrumentation and accessories shall not be connected to humans.

Before performing any maintenance, disconnect the line cord and all test cables.

To maintain protection from electric shock and fire, replacement components in mains circuits, including the power transformer, test leads, and input jacks, must be purchased from Keithley Instruments. Standard fuses, with applicable national safety approvals, may be used if the rating and type are the same. Other components that are not safety related may be purchased from other suppliers as long as they are equivalent to the original component. (Note that selected parts should be purchased only through Keithley Instruments to maintain accuracy and functionality of the product.) If you are unsure about the applicability of a replacement component, call a Keithley Instruments office for information.

To clean an instrument, use a damp cloth or mild, water based cleaner. Clean the exterior of the instrument only. Do not apply cleaner directly to the instrument or allow liquids to enter or spill on the instrument. Products that consist of a circuit board with no case or chassis (e.g., data acquisition board for installation into a computer) should never require cleaning if handled according to instructions. If the board becomes contaminated and operation is affected, the board should be returned to the factory for proper cleaning/servicing.

---

# Table of Contents

<b>1</b>	<b>General Information</b>	
	Introduction .....	1-2
	Feature overview .....	1-2
	Warranty information .....	1-2
	Manual addenda .....	1-2
	Safety symbols and terms .....	1-3
	Specifications .....	1-3
	Unpacking and inspection .....	1-3
	Inspection for damage .....	1-3
	Shipment contents .....	1-3
	Instruction manual .....	1-4
	Repacking for shipment .....	1-4
	Available accessories .....	1-4
	SMA cables and torque wrench .....	1-4
	Relay kits .....	1-4
	Replacement relays .....	1-5
	Connections .....	1-5
	Installation .....	1-5
	Rack mounting .....	1-5
	Foot mounting .....	1-6
<b>2</b>	<b>Connections</b>	
	Introduction .....	2-2
	Handling precautions .....	2-2
	System configuration .....	2-2
	Layout .....	2-2
	Simplified schematic .....	2-4
	Connections .....	2-4
	Signal connections .....	2-4
	GPIB control connection .....	2-6
	Power connections .....	2-8
	Ground connection .....	2-10
	Switching considerations .....	2-11
	Connector integrity .....	2-11
	Voltage standing wave ratio .....	2-11
	Path isolation .....	2-11
	Insertion loss .....	2-12
	RFI/EMI .....	2-12

---

## 3

### Operation

Introduction .....	3-2
Signal considerations .....	3-2
Bus operation (GPIB) .....	3-2
Bus connections .....	3-2
Primary address .....	3-3
Programming syntax .....	3-3
Response messages .....	3-7
GPIB commands .....	3-8
ROUTE commands .....	3-8
STATUs commands .....	3-11
SYSTem commands .....	3-14
Status model .....	3-16
Event register sets .....	3-17
Enable registers .....	3-18
Queues .....	3-18
Status byte and SRQ .....	3-20
Service request enable register .....	3-21
Serial polling and SRQ .....	3-21
Clearing registers and queues .....	3-22
Programming enable registers .....	3-23
Reading registers .....	3-23
Common commands .....	3-24
Errors .....	3-32

## 4

### Service Information

Introduction .....	4-2
Handling and cleaning precautions .....	4-2
Handling precautions .....	4-2
Circuit board and connector cleaning .....	4-3
Performance verification .....	4-3
Environmental conditions .....	4-3
Recommended equipment .....	4-4
Channel resistance tests .....	4-5
Replacing components .....	4-6
Replacing relays .....	4-6
Mainframe replacement parts .....	4-9
Replacement precautions .....	4-9
Soldering considerations .....	4-9
Disassembly .....	4-9



---

<b>5</b>	<b>Replaceable Parts</b>	
	Introduction .....	5-2
	Parts list .....	5-2
	Ordering information .....	5-2
	Factory service .....	5-2
	Component layout .....	5-2
<b>A</b>	<b>Specifications</b>	

---

# List of Illustrations

## 1 General Information

Figure 1-1	Rack preparation .....	1-6
------------	------------------------	-----

## 2 Connections

Figure 2-1	General layout (front panel) .....	2-3
Figure 2-2	General layout (rear panel) .....	2-3
Figure 2-3	Simplified schematic .....	2-4
Figure 2-4	Relay input/output connections .....	2-5
Figure 2-5	GPIB control connector .....	2-6
Figure 2-6	Power supply fuse .....	2-10

## 3 Operation

Figure 3-1	Primary address DIP switch example .....	3-3
Figure 3-2	Command diagram .....	3-5
Figure 3-3	Controlling relay connections .....	3-6
Figure 3-4	Status model structure .....	3-16
Figure 3-5	Standard event status .....	3-17
Figure 3-6	Status byte and service request (SRQ) .....	3-20
Figure 3-7	16-bit status register .....	3-23
Figure 3-8	Standard event enable register .....	3-26
Figure 3-9	Standard event status register .....	3-27
Figure 3-10	Service request enable register .....	3-29
Figure 3-11	Status byte register .....	3-30

## 4 Service Information

Figure 4-1	Custom made test lead set .....	4-4
Figure 4-2	Channel resistance test connections .....	4-5
Figure 4-3	SPDT relay mounting .....	4-7
Figure 4-4	Connecting control wires to SPDT relay .....	4-7
Figure 4-5	SP4T and SP6T relay mounting .....	4-8
Figure 4-6	S46 exploded view .....	4-10

---

## List of Tables

### 2

#### Connections

Table 2-1	Relay channel assignments .....	2-5
Table 2-2	GPIB control connector terminals .....	2-7
Table 2-3	Line fuse .....	2-9
Table 2-4	Power supply fuse .....	2-9

### 3

#### Operation

Table 3-1	Parameter types .....	3-4
Table 3-2	:ROUTe subsystem command set .....	3-8
Table 3-3	Relay channel assignments .....	3-9
Table 3-4	:STATus subsystem command set .....	3-11
Table 3-5	:SYSTem subsystem command set .....	3-14
Table 3-6	SCPI commands — error queue .....	3-19
Table 3-7	Common and SCPI commands — reset registers and clear queues .....	3-22
Table 3-8	IEEE-488.2 common commands and queries .....	3-24
Table 3-9	Error and status message .....	3-32

### 4

#### Service Information

Table 4-1	Recommended verification equipment .....	4-4
Table 4-2	Keithley part numbers for S46 relays .....	4-6

### 5

#### Replaceable Parts

Table 5-1	S46 digital board parts list .....	5-4
Table 5-2	S46 mechanical parts list .....	5-6

---

# 1 General Information

---

# Introduction

This section contains general information about the S46 Microwave Switch System. The information is organized as follows:

- Feature overview
- Warranty information
- Manual addenda
- Safety symbols and terms
- Specifications
- Unpacking and inspection
- Connections

If you have any questions after reviewing this information, please contact your local Keithley representative or call one of our Applications Engineers at 1-800-KEITHLEY. Worldwide phone numbers are listed at the front of this manual.

## Feature overview

The S46 is an IEEE-488 bus controlled 19-inch rack-mounted RF relay switch controller unit. Additional features of the S46 are as follows:

- Can be populated with up to eight 2-pole RF relays and a maximum of four, 3-pole, 4-pole, 5-pole, or 6-pole RF relays.
- LED indicators for error, power, and relay status.
- Operating range to 18GHz (relay dependent).

## Warranty information

Warranty information is located at the front of this instruction manual. Should your S46 require warranty service, contact the Keithley representative or authorized repair facility in your area for further information. When returning the S46 for repair, be sure to fill out and include the service form at the back of this manual to provide the repair facility with the necessary information.

## Manual addenda

Any improvements or changes concerning the S46 or manual will be explained in an addendum included with the manual. Be sure to note these changes and incorporate them into the manual.

## Safety symbols and terms

The following symbols and terms may be found on the S46 or used in this manual.

The  symbol indicates that the user should refer to the operating instructions located in the manual.

The  symbol shows that high voltage may be present on the terminal(s). Use standard safety precautions to avoid personal contact with these voltages.

The **WARNING** heading used in this manual explains dangers that might result in personal injury or death. Always read the associated information very carefully before performing the indicated procedure.

The **CAUTION** heading used in this manual explains hazards that could damage the switch. Such damage may invalidate the warranty.

## Specifications

Full S46 specifications are included in [Appendix A](#). Check the Keithley website ([www.keithley.com](http://www.keithley.com)) for latest updates to the specifications.

## Unpacking and inspection

### Inspection for damage

The S46 was carefully inspected electrically and mechanically before shipment. After unpacking all items from the shipping carton, check for any obvious signs of physical damage that may have occurred during transit. Report any damage to the shipping agent immediately. Save the original packing carton for possible future shipment.

### Shipment contents

The following items are included with every S46 order:

- S46 Microwave Switch System.
- Production Information CD-ROM that contains PDFs of this **Instruction Manual** and **Installation Instructions** for the Relay Kits (PA-778) (see “[Relay kits](#)” on [page 1-4](#)).
- Additional accessories as ordered.

## Instruction manual

A Production Information CD-ROM that contains this Instruction Manual can be ordered from Keithley. If a hardcopy of the S46 Instruction Manual is required, order the manual package, Keithley Part Number S46-901-00. The manual package includes an instruction manual and any pertinent addenda.

Always check the Keithley website ([www.keithley.com](http://www.keithley.com)) for the latest revision of the manual. The latest manual can be downloaded (in PDF format) from the website.

## Repacking for shipment

Should it become necessary to return the S46 for repair, carefully pack the unit in its original packing carton or the equivalent, and follow these instructions:

- Call the Repair Department at 1-800-552-1115 for a Return Material Authorization (RMA) number.
- Advise as to the warranty status of the S46.
- Write ATTENTION REPAIR DEPARTMENT and the RMA number on the shipping label.
- Fill out and include the Service Form located at the back of this manual.

## Available accessories

*NOTE Check the Keithley website ([www.keithley.com](http://www.keithley.com)) for additional accessories that may have been added to the Keithley product line for the S46.*

### SMA cables and torque wrench

- **S46-SMA-0.5** – Low loss, semi-flex SMA-to-SMA cable assembly, 0.152m (6 in.) in length.
- **S46-SMA-1** – Low loss, semi-flex SMA-to-SMA cable assembly, 0.305m (12 in.) in length.
- **S46-TW** – SMA cable torque wrench.

### Relay kits

Relays can be added to your test system by ordering relay kits from Keithley. Each kit includes a relay, a cable assembly, any necessary hardware, and installation instructions. The installation instructions (PA-778) are also provided on the CD that is supplied with the S46.

- **S46-SPDT-KIT** – SPDT relay and cable assembly.
- **S46-SP4T-KIT** – SP4T relay and cable assembly.
- **S46-SP6T-KIT** – SP6T relay and cable assembly.



## Replacement relays

A defective relay can be replaced by ordering the relay only:

- **RL-258** – SPDT relay.
- **RL-259-2** – SP4T relay.
- **RL-259-1** – SP6T relay.

*NOTE* The procedures for “[Replacing relays](#)” are provided in [Section 4](#).

## Connections

The following are available S46 connections:

- Female SMA coaxial connectors for all inputs and outputs on front panel.
- Power receptacle: standard 3-prong AC line connector on rear panel.
- GPIB port (IEEE-488 connector) on rear panel.

*NOTE* Refer to [Section 2](#) for detailed connection information.

## Installation

The S46 can either be mounted in a rack using the supplied rack mounting hardware or operated on a bench by installing the supplied feet as described below.

### Rack mounting

The S46 can be mounted in a standard 19-inch rack. The hardware necessary to install the unit in a rack is supplied with the S46.

#### Rack mount kit

The S46 is supplied with a Model 4288-7 rack mount kit, which mounts the unit in a standard 19-inch rack. This kit includes rear brackets to provide additional support for the unit.

## Rack mount procedure

Perform the following steps to install the S46 in the rack:

**WARNING** Make sure the S46 is turned off, the line cord is disconnected, and it is not connected to any external circuitry.

1. Select a location in the rack. The unit takes up 3.5 inches of vertical space.
2. Using [Figure 1-1](#) as a guide, install two retaining clips on the left front rail. Slide each retaining clip over a mounting hole such that the captive nut is positioned on the inside of the rack cabinet. In a similar manner, install two retaining clips on the right front rail.
3. If installed, remove the four feet from the bottom of the S46. Retain these feet for future use.
4. Position the S46 in the rack, and loosely attach the front panel to the rack rails using the four supplied dress screws.
5. Tighten the four dress screws.
6. Install and secure the rear brackets as outlined in the instructions supplied with the rack mount kit.

**CAUTION** Installation of the rear brackets is recommended to properly support the S46.

Figure 1-1  
**Rack preparation**

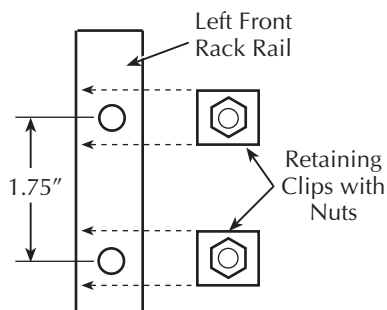

## Foot mounting

In the event the S46 is to be operated on a bench, the supplied rubber feet should be attached to the bottom of the unit. Each foot can be attached by removing the adhesive covering, and then pressing the foot into place in a suitable location near each corner on the bottom case cover. These feet should be removed before rack mounting the unit (see above).

2

# Connections

---

# Introduction

This section contains information about overall switch system configuration and connections and is organized as follows:

- Handling precautions
- System configuration
- Connections
- Switching considerations

**WARNING** The procedures in this section are intended only for qualified service personnel. Do not perform these procedures unless you are qualified to do so. Failure to recognize and observe normal safety precautions could result in personal injury or death.

## Handling precautions

To maintain high-impedance isolation, care should be taken when handling the S46 to avoid contamination from foreign materials such as body oils. Such contamination can reduce isolation resistance. To avoid possible contamination:

- Do not touch connector insulators.
- Operate the switch controller in a clean environment. If the unit becomes contaminated, it should be thoroughly cleaned as explained in [Section 4](#).

## System configuration

### Layout

[Figure 2-1](#) and [Figure 2-2](#) show the general layout of the S46 which features:

Connectors:

- Relay input and output connectors ([Figure 2-1](#)).
- Power line receptacle ([Figure 2-2](#)).
- GPIB Control: IEEE-488 interface connector ([Figure 2-2](#)).

Indicators ([Figure 2-1](#)):

- Relay state LEDs (one for each relay).
- Power LED.
- ERR LED (communication error or failed power on self-test).

Figure 2-1  
General layout (front panel)

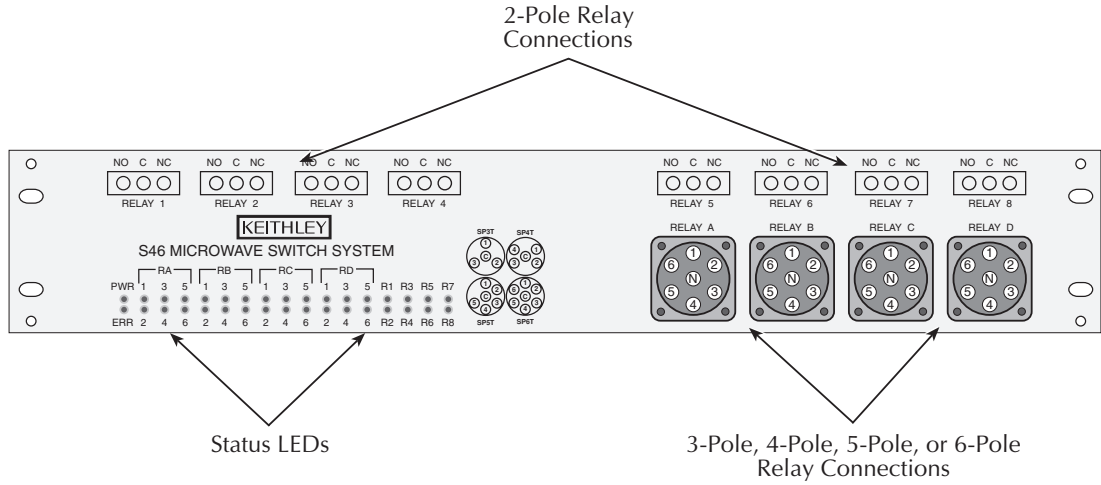
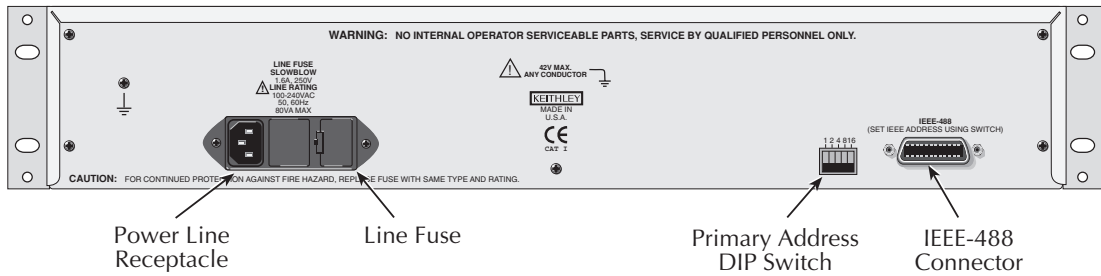

Figure 2-2  
General layout (rear panel)



## Simplified schematic

Figure 2-3 shows a simplified schematic diagram of the S46. Configuration is as follows:

- RELAY 1 through RELAY 8 are 2-pole relays, each with two inputs (normally closed and normally open) and one common.
- RELAY A through RELAY D can be 3-pole, 4-pole, 5-pole, or 6-pole relays, each with a maximum of six inputs and one common. The number of inputs depends on relay configuration, as shown by the dotted lines in the diagram.

Figure 2-3  
**Simplified schematic**

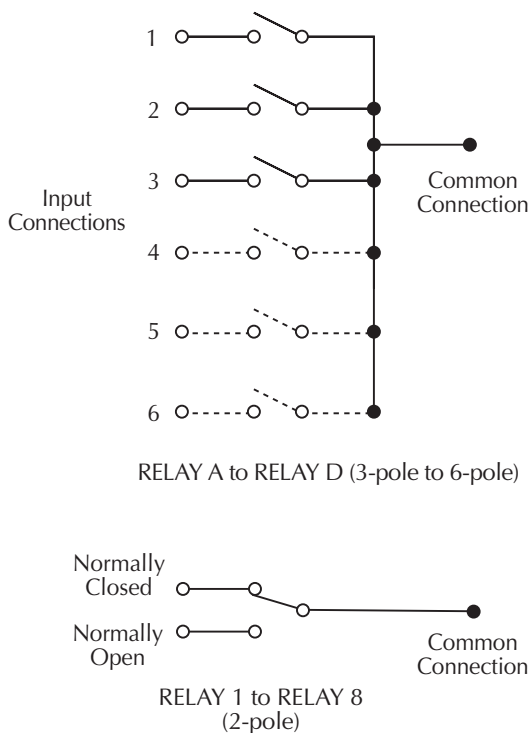

## Connections

### Signal connections

RF input and output connections are made either to the RELAY 1 through RELAY 8 connectors, or to the RELAY A through RELAY D connectors as outlined below. Each connector is an SMA female connector intended for use with 50Ω cable.

## Relay configuration

The S46 can be populated with relays as follows:

- RELAY A, B, C, and D can be populated with either 3-pole, 4-pole, 5-pole, or 6-pole relays.
- RELAY 1 through RELAY 8 are populated with 2-pole RF relays.
- Any or all relay locations can be populated.

## Channel assignments

Table 2-1 summarizes relay channel assignments. See Section 3 for information on controlling channels.

**NOTE** If RELAY A is populated with a 4-pole relay, closing channels 5 and 6 is not allowed. Regardless of the pole configuration of RELAY A, RELAY B starts numbering at channel 7.

Table 2-1

**Relay channel assignments**

Relay	Channels
RELAY A	1 through 6
RELAY B	7 through 12
RELAY C	13 through 18
RELAY D	19 through 24
RELAY 1 to 8	25 through 32

## Input/output connections

Figure 2-4 shows input and output connections for both RELAY A through RELAY D, and RELAY 1 through RELAY 8. RELAY A through RELAY B have up to six inputs and one output (depending on relay pole configuration). RELAY 1 through RELAY 8 each have two inputs and one output.

Figure 2-4

**Relay input/output connections**

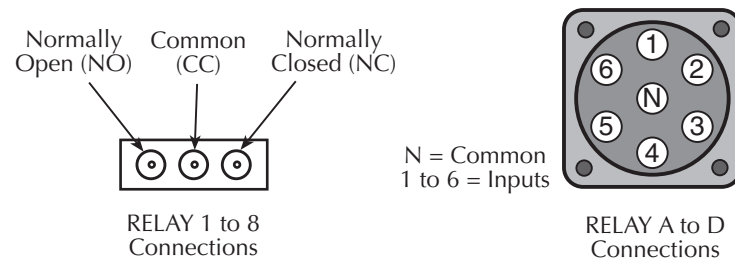

## GPIB control connection

The rear panel IEEE-488 (GPIB) control port is connected to the GPIB port of a computer (controller) using a shielded IEEE-488 interface cable with metric mating screws.

Figure 2-5 shows the connector, while Table 2-2 summarizes terminals.

Figure 2-5  
**GPIB control connector**

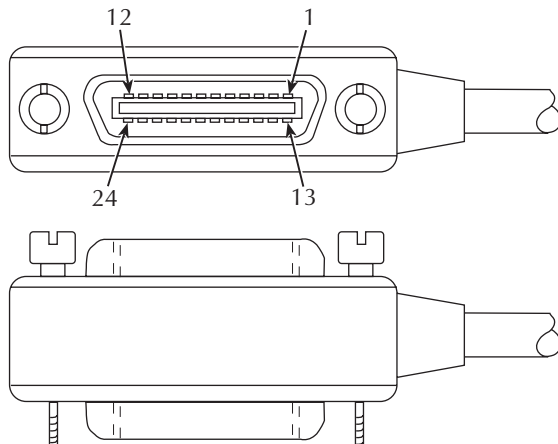

Remember the following restrictions when attaching instruments to the GPIB:

- A maximum separation of 4 meters between any two instruments on the bus.
- A maximum total cable length of 20 meters.
- No more than 15 devices on the bus.
- No two instruments having the same address.

If you cannot meet these requirements, the use of bus extenders is recommended.

**CAUTION** IEEE-488 common is connected to digital common. Maximum voltage between digital common and earth ground is 0V.

Connectors may be stacked to allow a number of parallel connections to one instrument. Two screws located on a standard connector maintain secure connections between connectors.

**NOTE** To minimize interference caused by electromagnetic radiation, use shielded IEEE-488 cables such as the Keithley Model 7007.



Connect devices to the GPIB as follows:

1. Line up the cable connector with the IEEE-488 connector located on the rear panel of the S46. The connector's design allows installation to the port in only one position.
2. Secure connector by tightening screws firmly (do not overtighten).
3. Add any additional connectors to the port as required.
4. Connect the free end of the cable to the controller.
5. Check that the primary address is properly set. (See [Section 3](#) of this manual for GPIB address information.)

Table 2-2

**GPIB control connector terminals**

Contact number	IEEE-488 designation	Type
1	DI01	Data
2	DI02	Data
3	DI03	Data
4	DI04	Data
5	EOI (24)*	Management
6	DAV	Handshake
7	NRFD	Handshake
8	NDAC	Handshake
9	IFC	Management
10	SRQ	Management
11	ATN	Management
12	SHIELD	Ground
13	DI05	Data
14	DI06	Data
15	DI07	Data
16	DI08	Data
17	REN (24)*	Management
18	Gnd (6) *	Ground
19	Gnd (7) *	Ground
20	Gnd (8) *	Ground
21	Gnd (9) *	Ground
22	Gnd (10) *	Ground
23	Gnd (11) *	Ground
24	Gnd, LOGIC	Ground

\* Numbers in parentheses refer to signal ground return of referenced contact number. EOI and REN signal lines return on contact 24.

## GPIB primary address

On the rear panel, there are five GPIB DIP switches to set the GPIB primary address. As shipped from the factory, the GPIB address is set to 7. Refer to [Section 3](#) of this manual for information on setting the primary address.

## Power connections

### Line voltage

The S46 operates from a line voltage in the range of 100V to 240V at a frequency of 50 or 60Hz. Line voltage selection is automatic.

**CAUTION** Operating the unit on an incorrect line voltage may cause damage, possibly voiding the warranty.

### Line power connection

Perform the following steps to connect the S46 to line power:

1. Connect the female end of the supplied power cord to the AC receptacle on the rear panel.
2. Connect the other end of the supplied power cord to a grounded AC outlet.

**WARNING** The power cord supplied with the S46 contains a separate ground for use with grounded outlets. When proper connections are made, instrument chassis is connected to power line ground through the ground wire in the power cord. Failure to use a grounded outlet may result in personal injury or death due to electric shock.

### Line fuse replacement

A rear panel fuse protects the power line input of the S46. If the line fuse needs replacement, perform the steps below:

**WARNING** Disconnect the line cord from the unit before changing the line fuse.

1. The fuse is located in a holder in the power module adjacent to the AC receptacle. (Figure 2-2.) At the right of the fuse holder is a small tab. At this location, use a small bladed screwdriver to release the fuse holder.
2. Slide the fuse holder out to gain access to the fuse carrier and fuse.

3. Remove the carrier with blown fuse, and replace the fuse with the correct type listed in [Table 2-3](#).

**CAUTION** For continued protection against fire or unit damage, replace the fuse only with the type and rating listed. If the unit repeatedly blows fuses, locate and correct the cause of the problem before replacing the fuse.

4. Install the fuse carrier in the fuse holder, then insert the fuse holder in the power module.

Table 2-3

**Line fuse**

Line voltage	Fuse rating	Keithley part no.
100-240V	1.6A slow blow, 250V, 5 X 20mm	FU-106-1.6

### Power supply fuse replacement

An internal fuse protects the output of the 28V DC power supply of the S46 from excessive current loads. If the internal power supply fuse needs replacement, perform the steps below:

**WARNING** Disconnect the line cord and all cables from the S46 before removing the top cover and replacing the power supply fuse.

1. Remove the screws that secure the top cover and remove it.
2. Refer to [Figure 2-6](#) to locate the in-line fuse holder.
3. Remove the fuse from the fuse holder.
4. Replace a blown fuse with one that has the fuse rating listed in [Table 2-4](#).
5. Replace the top cover.

**CAUTION** For continued protection against fire or unit damage, replace the fuse only with the type and rating listed. If the unit repeatedly blows fuses, locate and correct the cause of the problem before replacing the fuse.

Table 2-4

**Power supply fuse**

Fuse rating	Keithley part no.
1.6A slow blow, 250V, 5 X 20mm	FU-106-1.6

Figure 2-6  
**Power supply fuse**

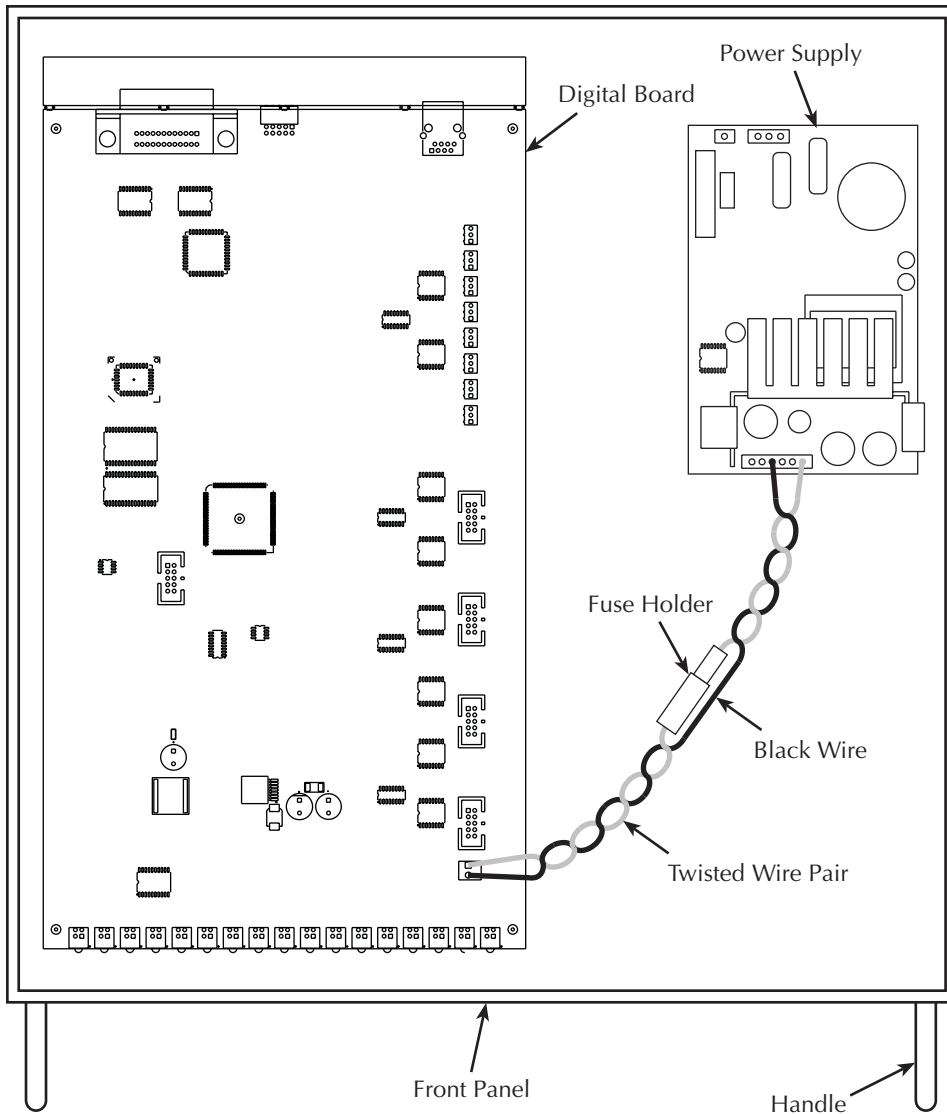

## Ground connection

The rear panel ground screw (Figure 2-2) should be connected to safety earth ground using #18 AWG or larger wire if the S46 is not mounted in a properly grounded rack.

## Switching considerations

Signals switched by the S46 may be subject to various effects that can seriously affect their integrity. The following paragraphs discuss these effects and ways to minimize them.

**CAUTION** Do not close more than one RF path per multi-port switch. Degradation of RF performance will result and the switch may be damaged.

### Connector integrity

As is the case with any high-resistance device, the integrity of connectors can be damaged if they are not handled properly. If connector insulation becomes contaminated, the insulation resistance will be substantially reduced, affecting high-impedance measurement paths. Refer to [Section 4](#) for cleaning information.

Oils and salts from the skin can contaminate connector insulators, reducing their resistance. Also, contaminants present in the air can be deposited on the insulator surface. To avoid these problems, never touch the connector insulating material. In addition, use the relay only in clean, dry environments to avoid contamination.

### Voltage standing wave ratio

The Voltage Standing Wave Ratio (VSWR) is a measurement of mismatch in a cable, waveguide, or antenna system. The measurement is shown as ratio to 1, e.g., a VSWR of 1.2 is actually the ratio of 1.2:1. Refer to the specifications located in [Appendix A](#) for S46 VSWR information.

### Path isolation

The path isolation is the equivalent impedance between any two test paths in a measurement system. Ideally, the path isolation should be infinite, but the actual resistance and distributed capacitance of cables and connectors results in less than infinite path isolation values for these devices.

Path isolation resistance forms a signal path that is in parallel with the equivalent resistance of the DUT. For low-to-medium device resistance values, path isolation resistance is seldom a consideration; however, it can seriously degrade measurement accuracy when testing high-impedance devices. The voltage measured across such a device, for example, can be substantially attenuated by the voltage divider action of the device source resistance and path isolation resistance. Also, leakage currents can be generated through these resistances by voltage sources in the system. Refer to the specifications located in [Appendix A](#) for S46 isolation information.

## Insertion loss

Insertion loss indicates signal lost while passing through the switch. This loss occurs in the various signal path components through the switch connectors, PC board traces, and relay. Refer to the specifications in [Appendix A](#) for S46 insertion loss information.

## RFI/EMI

RFI (Radio Frequency Interference) and EMI (Electromagnetic Interference) are general terms used to describe electromagnetic interference over a wide range of frequencies across the spectrum. Such interference can be particularly troublesome at low signal levels, but it can also affect measurements at high levels if the problem is of sufficient severity.

EMI can be caused by steady-state sources such as radio or TV broadcast signals, or some types of electronic equipment (microprocessors, high speed digital circuits, etc.), or it can result from impulse sources, as in the case of arcing in high-voltage environments. In either case, the effect on the desired signal can be considerable if enough of the unwanted signal is present.

EMI can be minimized in several ways. The most obvious method is to keep the equipment and signal leads as far away from the RFI source as possible. Shielding the switching switch, signal leads, sources, and measuring instruments will often reduce RFI to an acceptable level. In extreme cases, a specially constructed screen room may be required to sufficiently attenuate the troublesome signal.

# 3 Operation

---

# Introduction

This section contains the following operating information for the S46:

- Maximum signal considerations
- Bus operation
- GPIB commands
- Status model
- Programming enable registers
- Common commands
- Errors

## Signal considerations

**WARNING** Maximum voltage between any conductor and ground is 42V.

**CAUTION** To prevent damage to the S46, do not exceed the following maximum signal level specifications of the switch:

- Maximum Voltage: 30VDC, 42V peak
- Maximum Power (per RF channel): 35W CW @ 18GHz, 1W switching. Load VSWR of 1.20:1 maximum.

**CAUTION** Do not close more than one RF path per multi-port switch. Degradation of RF performance will result and the switch may be damaged.

## Bus operation (GPIB)

**NOTE** The term GPIB (*General Purpose Interface Bus*) is used in this manual. GPIB is simply another term for the IEEE-488 bus.

### Bus connections

Before using the S46, you must connect the IEEE-488 connector on the rear panel of the switch to the IEEE-488 connector of the controller. Use a Keithley Model 7007 or similar shielded IEEE-488 cable for this connection. Refer to [Section 2](#) for more information on the IEEE-488 connection.







## Primary address

The primary address of the S46 must agree with the primary address you intend to specify in the controller's programming language. There are five GPIB address DIP switches located on the rear panel adjacent to the IEEE-488 connector. When shipped from the factory, the GPIB address is set to 7. As shown in [Figure 3-1](#), these switches use a binary weighted configuration.

**NOTE** *Momentarily remove power from the unit after changing the address to update the address to the new setting.*

Figure 3-1  
**Primary address DIP switch example**

Binary Weight	Decimal Weight		ON →	Decimal Value	
00001	1	LSB		0	
00010	2			0	
00100	4			4	
01000	8			0	
10000	16	MSB		+ 16	
				20	GPIB Address

Note: There is no GPIB address of 31 (if the switches are set to 31, they will be interpreted as being set to 30).

## Programming syntax

Syntax rules for programming the S46 are covered in this paragraph.

### Commands and parameters

The general form for SCPI commands is demonstrated in [Table 3-2](#) through [Table 3-4](#). They are hierarchical in nature and begin with a root command. For example, to open all channels for relays 1 and 2, send the following command:

```
:OPEN:ALL
```

The root path command for the above example is ROUTE. This is an optional command word (as indicated by the brackets ([ ]) in the table) and need not be used.

The general form for Common Commands is shown in [Table 3-4](#) discussed later in this section.

**NOTE** *Each common command is preceded by a star (\*).*

Parameters provide specific types of information. The following list (Table 3-1) contains the definitions of the different parameter types.

Table 3-1  
**Parameter types**

Parameter	Description
<name>	Name parameter: Select a parameter name from a listed group.
<clist>	List of channels. The following examples demonstrate proper format: (@1,7) Channels 1 and 7.
<b>	Boolean: Enable (1 or on) or disable (0 or off) a function.
<NRf>	Numeric representation format: Number can be expressed as an integer, real number or an exponent (e.g. 2.3E6).
<n>	Numeric value: An NRf number or one of the following name parameters: <ul style="list-style-type: none"> <li>-DEFault: Uses the *RST default parameter value</li> <li>-MINimum: Uses the lowest allowable parameter value</li> <li>-MAXimum: Uses the largest allowable parameter value</li> </ul>

### Short-form commands

Most SCPI command words and name parameters have a short-form version. The short-form versions are identified in the SCPI tables by the upper case characters. Example:

```
:ROUT:CLOS (@1,7) = :ROUTE:CLOSE (@1,7)
```

**NOTE** Command words and parameter names are not case sensitive.

### Query commands

Query commands request information (queries) and can be identified by the question mark appearing after the command (?). Example:

```
:CLOSE? Queries the channels that are closed.
```

### Command messages

**Program Message** — A program message is made up of one or more command words sent by the computer to the instrument. Some programming operations require several command words.

**Single Command Message** — This program message uses the command words required to perform a single programming operation. Example:

```
:SYST:ERR? Reads the system error queue.
```

**Multiple Command Message** — This program message contains two or more command operations. Each command string is separated by a semicolon (;). The following example uses the short-form format to reduce the size of the message:

```
:ROUT:CLOS (@1,7);:ROUT:CLOS?
```

The above program message closes channel 1 and 7, and then queries for closed relays.

### Example command

To connect channels 2 and 8:

```
:ROUT:CLOS (@2,8);
```

Refer to [Figure 3-2](#) for a diagram of the parts of this command and to [Figure 3-3](#) for an illustration of the physical connections.

Figure 3-2

#### Command diagram

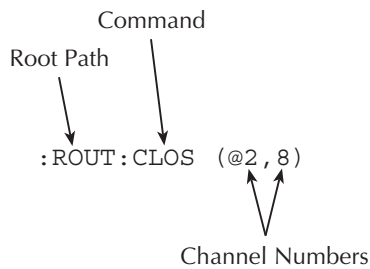

In this example, commands to close channels 2 and 8 are sent, which closes inputs to both RELAY A and RELAY B.

### Program message terminator (PMT)

Each program message must be terminated with a LF (line feed), EOI (end or identify), or a LF + EOI. The bus will hang if your computer does not provide this termination. The following example shows how a program message must be terminated:

```
open:all <PMT>
```

Figure 3-3  
**Controlling relay connections**

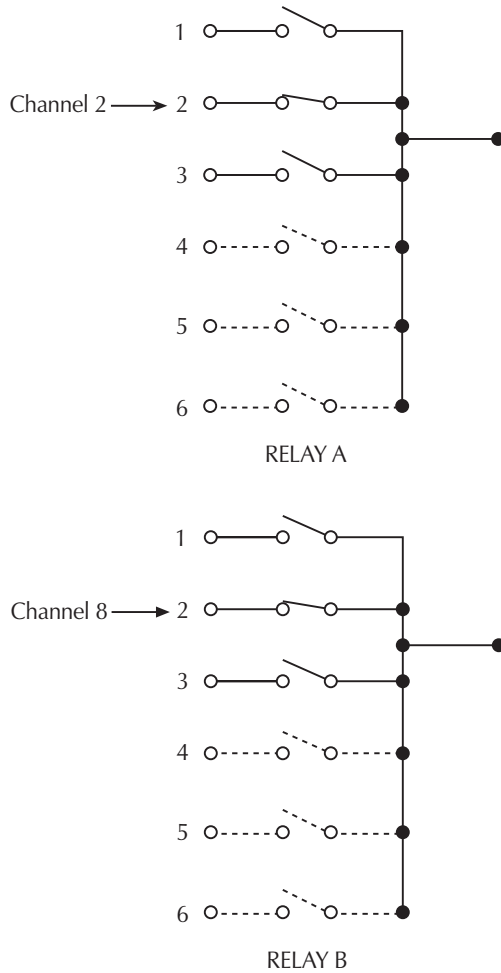

### Command execution rules

- Commands execute in the order presented in the program message.
- An invalid command generates an error and is not executed.
- Valid commands preceding an invalid command in a multiple command program message are executed.
- Valid commands following an invalid command in a multiple command program message are ignored.

## Response messages

A response message is the message sent by the instrument to the computer in response to a query command program message.

### Sending a response message

After sending a query command, the response message is placed in the output queue. When the relay unit is then addressed to talk, the response message is sent from the output queue to the computer.

### Multiple response messages

If you send more than one query command in the same program message, the multiple response messages for all the queries are sent to the computer when the relay unit is addressed to talk. The responses are sent in the order the query commands were sent and are separated by semicolons (;). Items within the same query are separated by commas (,). The following example shows the response message for a program message that contains four single item query commands:

```
0;1;1;0
```

### Response message terminator (RMT)

Each response is terminated with an LF (line feed) and EOI (end or identify). The following example shows how a multiple response message is terminated:

```
0;1;1;0 <RMT>
```

## Message exchange protocol

Two rules summarize the message exchange protocol:

- Rule 1: You must always tell the S46 what to send to the computer.
- Perform the following two steps to send information from the unit to the computer:
1. Send the appropriate query command(s) in a program message.
  2. Address the S46 to talk.
- Rule 2: The computer must receive the complete response message before another program message can be sent to the unit.

## GPIB commands

This section contains S46 specific commands for the three different subsystems as follows: “[ROUTE commands](#)”, “[STATus commands](#)”, and “[SYSTem commands](#)”.

### ROUTE commands

A list of the ROUTe commands is contained in [Table 3-2](#). ROUTe commands are used to open and close channels, query closed channels, and to read and reset the relay closure count. The brackets indicate that [:ROUTE] is optional and need not be included in the command message. Following the table are details defining the use of the specific ROUTe subsystem commands.

Table 3-2

#### **:ROUTE subsystem command set**

Commands	Description
[:ROUTE]	Root path to :ROUTE subsystem commands.
:CLOSE <clist>	Enter the list of channels to close.
:CLOSE?	Query which channel(s) are closed. Returns a <clist> of closed channels.
:COUNT?	Returns 32 comma-separated variables representing the closure count on each of the 32 channels.
:RCOUNT <clist>	Resets (sets to zero) the closure count for channels specified in <clist>.
:OPEN <clist>	Enter the list of channels to open.
:ALL	Opens all channels.
:CONFigure	Path to configuration commands.
:CPOLe <clist>	Define which relays are present in system.
:CPOLe?	Query which relays are present in system.
:SPARAmeterN <string>	Stores s-parameter string for channel N (N=1-32). 68 characters max.
:SPARAmeterN?	Returns stored s-parameter string for channel N (1-32) with no delimiters.

**:CLOSE <clist>**

**Close channel(s)**

**:CLOSE?**

**Query closed channel(s)**

**Parameters**

<clist> = (@ chanlist)  
where *chanlist* is the list of channels to be closed separated by commas.

**Description**

Enter the list of channels to close in a <clist>. For example, if you want to close channels 2 and 7, send ROUT:CLOS (@2,7). [Table 3-3](#) summarizes channel assignments.

**CAUTION**

Do not close more than one RF path per multi-port switch. Degradation of RF performance will result and the switch may be damaged.

**Query** This query command is used to return a <clist> of presently closed channel(s). For example, if channels 2 and 7 are closed and ROUT:CLOS? is sent, then the query will return (@2,7).

Table 3-3  
**Relay channel assignments**

Relay	Channels
RELAY A	1 through 6
RELAY B	7 through 12
RELAY C	13 through 18
RELAY D	19 through 24
RELAY 1 to 8	25 through 32

### **:COUNT?**

### **Return closure count**

**Description** This command (query only) is used to return 32 comma-separated values representing closure count (the number of times the channel has been closed). Unpopulated channels always have a count of zero. To reset this count, see RCOunt.

### **:RCOunt <clist>**

### **Reset closure count for channel(s)**

**Parameters** <clist> = (@ chanlist)  
where *chanlist* is the list of channels to be reset.

**Description** This command is used to reset closure count in a <clist>. For example, to reset the closure count values for channels 1 and 4, send :ROUT:CLOS:RCO (@1,4).

**Query** No query form of this command exists.

### **:OPEN <clist>**

### **Open channel(s)**

**Parameters** <clist> = (@ chanlist)  
where *chanlist* is the list of channels to be opened.

**Description** Enter the list of channels to open in a <clist>. For example, if you want to open channels 2 and 7, send ROUT:OPEN (@2,7).

**Query** No query form of this command exists.

<b>:OPEN:ALL</b>	<b>Opens all channels</b>
<b>Description</b>	Use this command to open all channels simultaneously.
<b>Query</b>	No query form of this command exists.
<b>:CONfigure:CPOLe &lt;clist&gt;</b>	<b>Define relays present in system</b>
<b>Parameters</b>	<clist> = (@ chanlist) where <i>chanlist</i> is the list of relay channels present in the system.
<b>Description</b>	This command is used to define which relays are present in the system as a <clist>. This command need be used only if the system is being configured differently from the factory shipped relay configuration. <clist> is defined as follows: clist = (@0   3-6, 0   3-6, 0   3-6, 0   3-6, 0   1, ... 0   1) A      B      C      D      1 ... 8 Note that all switch locations must be included in the <clist>. For example, if RELAY A and RELAY B are SP6T, RELAY 1 and RELAY 2 are SPDTs, and all others are not populated, the command syntax would be: :ROUT:CONF:CPOL (@6,6,0,0,1,1,0,0,0,0,0,0)
<b>Query</b>	This query returns the relay configuration pole information with the form factor defined above.
<b>:CONfigure:SPARAmeterN &lt;string&gt;</b>	<b>Define s-parameter string</b>
<b>Parameters</b>	<string> = ASCII string of up to 68 characters representing s-parameters enclosed in single or double quotes (both quotes must be the same type).
<b>Description</b>	This command allows you to store a string of up to 68 characters representing s-parameters for channel N (N=1 to 32). For example, the following command stores s-parameters for channel 10: :ROUT:CONF:SPAR10 "<s-parameters>"
<b>Query</b>	This query returns the stored s-parameter string for channel N with no delimiters.



## STATUS commands

A list of the STATUS commands is contained in Table 3-4. STATUS commands are used to control the status registers of the S46. Following the table are details defining the use of the specific STATUS subsystem commands.

**NOTE** See “*Status model*” later in this section for more details.

The :STATUS command path is required to access all commands contained in the :STATUS subsystem command set. To send any of the commands contained in the :STATUS subsystem command set, include the command path immediately before the command. For an example, see the description of the specific command.

Table 3-4

### **:STATUS subsystem command set**

Commands	Description
:STATUS	Root path to :STATUS subsystem commands.
:PRESet	Return status registers to default states.
:QUEue	Path to access error queue.
[:NEXT]?	Read the most recent error message.
:ENABle <clist>	Specify error and status messages for queue.
:ENABle?	Read the enabled messages.
:DISABle <clist>	Specify messages not to be placed in queue.
:DISABle?	Read the disabled messages.
:CLEar	Clear all messages from the error queue.

### **:PRESet**

#### **Reset status registers to default states**

**Description** Use this command to return all status registers to their default states. For example, to reset all status registers to their default states, send:  
:STAT:PRES

**Query** No query form of this command exists.

### **:QUEue**

#### **Path to queue commands**

This command path is required to access the following error queue commands. To send any of the following commands, include the command path immediately before the command. For an example, see the descriptions.

**[ :NEXT ]?****Read most recent error**

**NOTE** The `:STAT:QUE:NEXT?` is equivalent to the `:SYSTEM:ERROR?` command. See the `SYSTEM` subsystem for more information.

**Description** Use this query to read messages placed in the error queue. For example, send:

```
:STAT:QUE:NEXT?
```

After this command is sent and the S46 is addressed to talk, the “oldest” message in the queue is sent to the computer.

The queue holds up to 10 messages. The error queue is a FIFO (first-in, first-out) register. Every time the error queue is queried, the oldest message is read and removed from the queue. If the error queue becomes full, the message “350, ‘Queue Overflow’ ” will occupy the last memory location in the register. On power up, the error queue is empty. If empty, the message “0, ‘No Error’ ” is placed in the error queue. The messages in the error queue are preceded by a number. Refer to [Table 3-9](#) for a listing of error numbers and messages.

**:ENABLE <list>****Enable error queue messages****:ENABLE?****Query for enabled error queue messages**

**Parameters** <list> = (numlist)

where *numlist* is a comma-separated list of messages desired to be enabled for the error queue. See [Table 3-9](#) for a list of error and status numbers.

**Description** Use this command to specify status and error messages enabled for the error queue. On power-up, status messages are *not* enabled and therefore are prevented from going into the queue. All other error messages are enabled and will go into the error queue as they occur. When this command is sent, all messages are first disabled, then the messages specified in the list are enabled. For example, to enable only the -110, -140, and -222 messages, send:

```
:STAT:QUE:ENAB (-110, -140, -222)
```

To disable all messages from entering the error queue, send:

```
:STAT:QUE:ENAB ()
```

**Query** This query command is used to return a list of the presently enabled error messages.

<b>:DISable &lt;list&gt;</b>	<b>Disable error queue messages</b>
<b>:DISable?</b>	<b>Query for disable error queue messages</b>
<b>Parameters</b>	<list> = (numlist) where <i>numlist</i> is a comma-separated list of messages desired to be enabled for the error queue. See <a href="#">Table 3-9</a> for a list of error and status numbers.
<b>Description</b>	Use this command to specify status and error messages disabled for the error queue. On power-up, status messages are <i>not</i> enabled and therefore are prevented from going into the queue. All other error messages are enabled and will go into the error queue as they occur unless disabled. For example, to disable the -110, -140, and -222 messages, send: :STAT:QUE:DIS (-110,-140,-222)
<b>Query</b>	This query command is used to return a list of the presently disabled error messages.
<b>:CLEar</b>	<b>Clear all messages from the error queue</b>
<b>Description</b>	Use this command to clear all messages from the error queue. For example, to clear all messages from the error queue, send: :STAT:QUE:CLE
<b>Query</b>	No query form of this command exists.

## SYSTEM commands

A list of the SYSTEM commands is contained in [Table 3-5](#). The SYSTEM command subsystem contains miscellaneous commands.

The :SYSTEM command path is required to access all commands contained in the :SYSTEM subsystem command set. To send any of the commands contained in the :SYSTEM subsystem command set, include the command path before the command. For an example, see the description of the specific command.

Table 3-5

### :SYSTEM subsystem command set

Commands	Description
:SYSTEM	Root path to :SYSTEM subsystem commands.
:ERRor?	Query system error queue.
:VERsion?	Query SCPI version.
:CLEar	Clear messages in error queue.
:SNUMber?	Query the serial number only.

### :ERRor?

#### Query most recent error

**NOTE** The `:SYST:ERR?` is equivalent to the `:STATus:QUEue:NEXT?` command. See the `STATus` subsystem for more information.

#### Description

Use this query to read messages placed in the error queue. For example, send:

```
:SYST:ERR?
```

After this command is sent and the S46 is addressed to talk, the “oldest” message in the queue is sent to the computer.

The queue holds up to 10 messages. The error queue is a FIFO (first-in, first-out) register. Every time the error queue is queried, the oldest message is read and removed from the queue. If the error queue becomes full, the message “350, ‘Queue Overflow’ ” will occupy the last memory location in the register. On power up, the error queue is empty. If empty, the message “0, ‘No Error’ ” is placed in the error queue. The messages in the error queue are preceded by a number. Refer to [Table 3-9](#) for a listing of error numbers and messages.

### :VERsion?

#### Query SCPI version

#### Description

Use this query to read the version of the SCPI standard being used by the S46. For example, send:

```
:SYST:VER?
```

<b>:CLEar</b>	<b>Clear all messages from the error queue</b>
<b>Description</b>	Use this command to clear all messages from the error queue. For example, send: :SYST:CLE
<b>Query</b>	No query form of this command exists.
<b>:SNUMBER?</b>	<b>Query the serial number</b>
<b>Description</b>	Use this query to read the S46 serial number. For example, send: :SYST:SNUM

# Status model

The S46 provides status registers and queues allowing the operator to monitor and manipulate the various instrument events. The status structure is shown in Figure 3-4. The heart of the status structure is the status byte register. This register can be read by the user's test program to determine if a service request (SRQ) has occurred, and what event caused it.

Figure 3-4  
Status model structure

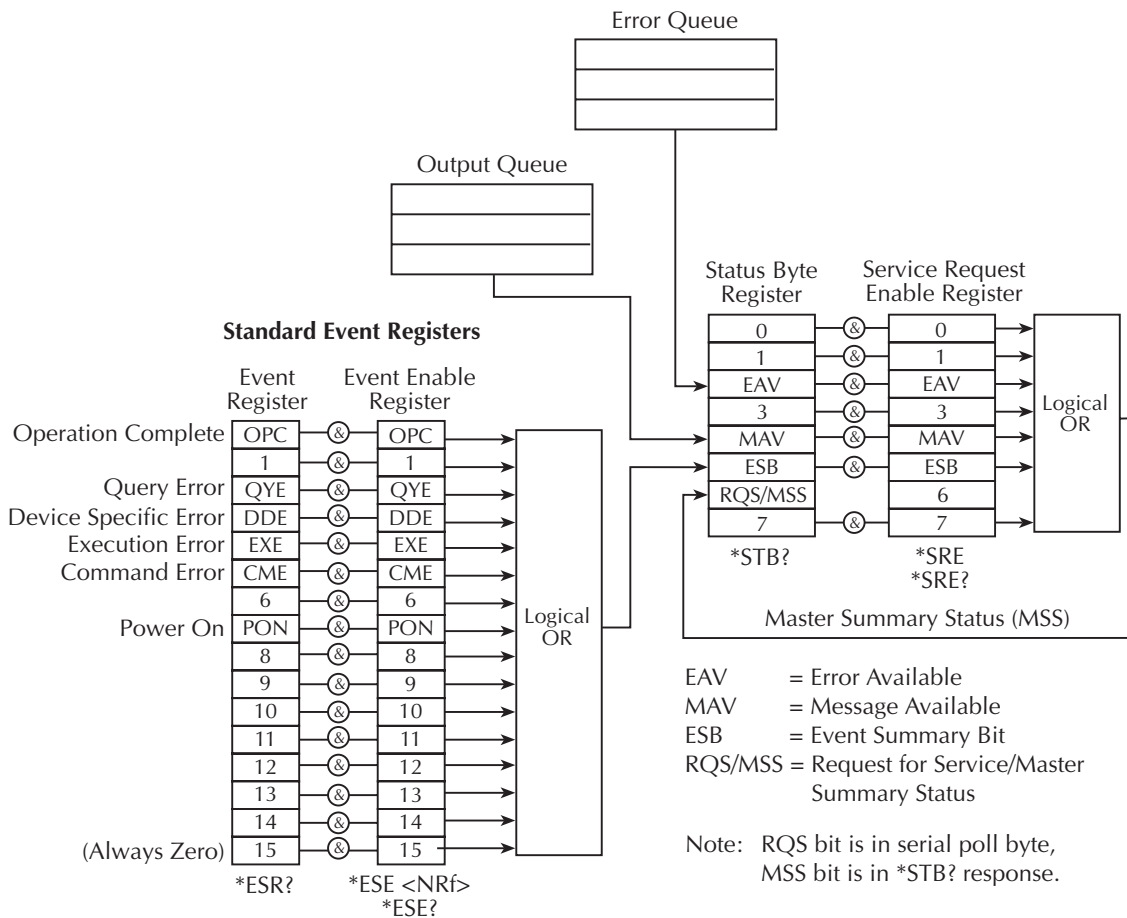



## Enable registers

The enable register is user programmed and serves as a mask for the corresponding event register. An even bit is masked when the corresponding bit in the enable register is cleared (0). When masked, a set bit in an event register cannot set a bit in the status byte register ( $1 \text{ AND } 0 = 0$ ).

To use the status byte register to detect events (i.e., serial poll), unmask the events by setting the appropriate bits of the enable registers.

Use \*ESE and \*ESE? (common commands) to program and read the standard event register.

## Queues

The relay unit uses an output queue and an error queue. The response messages to query commands are placed in the output queue. As various programming errors and status messages occur, they are placed in the error queue (this queue holds up to ten messages). When a queue contains data, it sets the appropriate summary bit of the status byte register.

### Output queue

When data is placed in the output queue, the message available bit (MAV) in the status byte register sets. A data message is cleared from the output queue when it is read. The output queue is considered cleared when it is empty. A cleared output queue clears the MAV bit in the status byte register. A message is read from the output queue by addressing the unit to talk after the appropriate query is sent.

The following command sequence enables the MAV bit (B4) of the status byte register set and then causes an SRQ:

```
*SRE 16'Enable MAV bit of the status byte to cause an SRQ.
Language specific'Send a query command to the unit.
Language specific'Wait for an SRQ indicating ready to read.
Language specific'Read the query response.
```

### Error queue

When a message is placed in the error queue, the error available bit (EAV) in the status byte register sets. An error/status message is cleared from the error queue when it is read. The error queue is considered cleared when it is empty. A cleared error queue clears the EAV bit in the status byte register.

Read an error message from the error queue by sending either of the following SCPI query commands and then addressing the S46 to talk:

```
:SYSTem:ERRor?
:STATus:QUEue?
```



Messages in the error queue are stored in a FIFO (First In-First Out) manner. The commands to read the error queue are listed in Table 3-6. When you read a single message in the error queue, the “oldest” message is read and then removed from the queue. If the queue becomes full, the message “350, ‘Queue Overflow’” will occupy the last memory location. On power-up, the error queue is empty. When empty, the message “0, No Error” is placed in the queue.

Messages in the error queue are preceded by a code number. Negative (-) numbers are used for SCPI defined messages, and positive (+) numbers are used for Keithley defined messages. The error messages are listed in Table 3-9.

On power-up, all error messages are enabled and will go into the error queue as they occur. Status messages are not enabled and will not go into the queue. As listed in Table 3-6, there are commands to enable and/or disable messages. For these commands, the <list> parameter is used to specify which messages to enable or disable. The messages are specified by their codes. The following examples show various forms for using the <list> parameter.

```
<list> = (-110)           Single message
        = (-110,-222,-220) Comma separated entries
```

When you enable messages, messages not specified in the list are disabled. When you disable messages, each listed message is removed from the enabled list.

**NOTE** To prevent all messages from entering the error queue, send the enable command along with the null list parameter as follows: `STATus:QUEue:ENABLE()`.

Table 3-6

**SCPI commands — error queue**

Command	Description	Default
STATus :QUEue [:NEXT]? :ENABle<list> :ENABle? :DISABle<list> :DISABle? :CLEar	STATus subsystem: Read error queue: Read and clear oldest error/status message. Specify error and status messages for error queue. Read the enabled messages. Specify messages not to be placed in queue. Read the disabled messages. Clear messages from error queue.	(Note 1)  (Note 2)  (Note 2)
SYSTem :ERRor? :CLEar	SYSTem subsystem: Read error queue: Clear messages from error queue.	(Note 1)

Notes:

1. Power-up and \*CLS empties the error queue. STATus:PRESet has no effect.
2. Power-up enables error messages and disables status messages. \*CLS and STATus:PRESet have no effect.

For more information on these commands, see the specific command listing in the SCPI command section.

## Status byte and SRQ

Service request is controlled by two 8-bit registers: the Status Byte Register and the Service Request Enable Registers. Figure 3-6 shows the structure for these registers.

Figure 3-6  
Status byte and service request (SRQ)

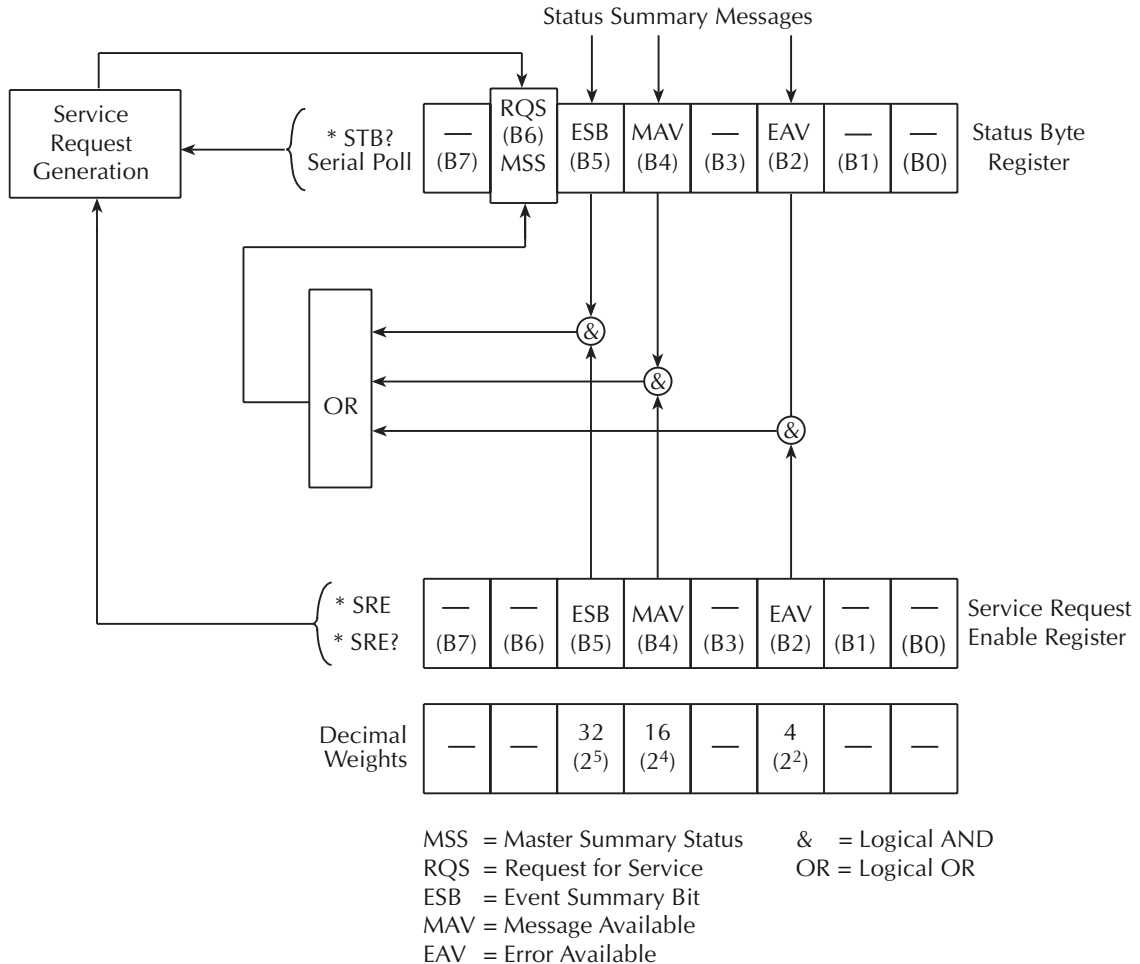

### Status byte register

The summary messages from the status registers and queues are used to set or clear the appropriate bits (B2, B4, B5, and B6) of the status byte register. These summary bits do not latch, and their states (0 or 1) are solely dependent on the summary messages (0 or 1).

For example, if the standard event register is read, its register will clear. As a result, its summary message will reset to 0, which in turn will reset the ESB bit in the status byte register.

Depending on how it is used, Bit B6 of the status byte register is either the request for service (RQS) bit or the Master Summary Status (MSS) bit:

When using the serial poll sequence of the relay unit to obtain the status byte (a.k.a. serial poll byte), B6 is the RQS bit. See “[Serial polling and SRQ](#)” for details on using the serial poll sequence.

When using the \*STB? command (see [Figure 3-5](#)) to read the status byte, B6 is the MSS bit.

The status byte register receives the summary bits of the Standard Event Register set and two queues. The register set and queues monitor the various instrument events. When an enabled event occurs, it sets a summary bit in the status byte register. When a summary bit of the status byte is set and its corresponding enable bit is set (as programmed by the user), the RQS/MSS bit will set to indicate that an SRQ has occurred.

## Service request enable register

The generation of a service request is controlled by the service request enable register. This register is programmed by the user and is used to enable or disable the setting of bit B6 (RQS/MSS) by the status summary message bits (B2, B4, B5, and B6) of the status byte register. As shown in [Figure 3-6](#), the summary bits are logically ANDed (&) with the corresponding enable bits of the service request enable register. When a set (1) summary bit is ANDed with an enabled (1) bit of the enable register, the logic “1” output is applied to the input of the OR gate and, therefore, sets the MSS/RQS bit in the status byte register.

The individual bits of the service request enable register can be set or cleared by using the \*SRE common command. To read the service request enable register, use the \*SRE? query command. The service request enable register clears when power is cycled or a parameter value of 0 is sent with the \*SRE command (i.e. \*SRE 0). The commands to program and read the SRQ enable register are listed in [Table 3-8](#).

## Serial polling and SRQ

Any enabled event summary bit that goes from 0 to 1 will set bit B6 and generate an SRQ (service request). In your test program, you can periodically read the status byte to check if an SRQ has occurred and what caused it. If an SRQ occurs, the program can, for example, branch to an appropriate subroutine that will service the request.

Typically, SRQs are managed by the serial poll sequence of the relay unit. If an SRQ does not occur, bit B6 (RQS) of the status byte register will remain cleared, and the program will simply proceed normally after the serial poll is performed. If an SRQ does occur, bit

B6 of the status byte register will set, and the program can branch to a service subroutine when the SRQ is detected by the serial poll.

The serial poll automatically resets RQS of the status byte register. This allows subsequent serial polls to monitor bit B6 for an SRQ occurrence generated by other event types. After a serial poll, the same event can cause another SRQ, even if the event register that caused the first SRQ has not been cleared.

The serial poll does not clear MSS. The MSS bit stays set until all status byte summary bits are reset.

## Clearing registers and queues

When the S46 is powered up, the bits of all registers in the status structure are clear (set to 0) and the two queues are empty. Commands to reset the event and event enable registers, and the error queue are listed in [Table 3-7](#). In addition to these commands, any enable register can be reset by sending the 0 parameter value with the individual command to program the register.

**NOTE** \*RST has no effect on status structure registers and queues. See “[Queues](#)” for details on the error queue.

Table 3-7

### Common and SCPI commands — reset registers and clear queues

Commands	Description	Ref
To reset Standard event register: *ESE 0 or *CLS	Reset all bits of the Standard Event Register to 0.	Note 1
To clear error queue: *CLS	Clear all messages from error queue.	Note 1
STATus :QUEue { :NEXT }? :CLEar	STATus subsystem: Error queue: Read and clear the oldest error/status message. Clear all messages from error queue.	Note 2
SYSTem :ERROR? :CLEar	SYSTem subsystem: Read and clear the oldest error/status message. Clear all messages from error queue.	Note 2

Notes:

1. The standard event enable register is not reset by STATus:PRESet (see “[Status byte and SRQ](#)”).
2. STATus:PRESet has no effect on the error queue.
3. Use either of the two :CLEar commands to clear the error queue.

## Programming enable registers

The registers that can be programmed by the user are the enable registers. All other registers in the status structure are read-only registers. The following explains how to ascertain the parameter value for the various commands used to program enable registers. The actual commands are covered later in this section (see [Table 3-8](#)).

A command to program an event enable register is sent with a decimal parameter value that determines the desired state (0 or 1) of each bit in the appropriate register. The bit positions of the register indicate the parameter value in binary format. For example, if you wish to set bits B5, B4, and B2 (set the bit's value to 1), the binary value would be 110100 (where B5=1, B4=1, B3=0, B2=1, B1=0, B0=0 and all other bits are 0). The decimal equivalent of binary 110100 is 52. Therefore, the parameter value for the enable command is 52.

Another way to determine the decimal value is to add up the decimal weights for the bits that you wish to set. Note that [Figure 3-7](#) includes the decimal weight for each register bit. To set bits B5, B3, and B2, the parameter value would be the sum of the decimal weights for those bits ( $32+16+4 = 52$ ).

*Figure 3-7*  
**16-bit status register**

Bit Position	B7	B6	B5	B4	B3	B2	B1	B0
Binary Value	0/1	0/1	0/1	0/1	0/1	0/1	0/1	0/1
Decimal Weights	128 ( $2^7$ )	64 ( $2^6$ )	32 ( $2^5$ )	16 ( $2^4$ )	8 ( $2^3$ )	4 ( $2^2$ )	2 ( $2^1$ )	1 ( $2^0$ )

### A. Bits 0 through 7

Bit Position	B15	B14	B13	B12	B11	B10	B9	B8
Binary Value	0/1	0/1	0/1	0/1	0/1	0/1	0/1	0/1
Decimal Weights	32768 ( $2^{15}$ )	16384 ( $2^{14}$ )	8192 ( $2^{13}$ )	4096 ( $2^{12}$ )	2048 ( $2^{11}$ )	1024 ( $2^{10}$ )	512 ( $2^9$ )	256 ( $2^8$ )

### B. Bits 8 through 15

## Reading registers

Any register in the status structure can be read by using the appropriate query (?) command. The specific query commands are covered later in this section (see [Table 3-8](#)).

The response message to the query command is a decimal value. To determine which bits in the register are set, convert that decimal value to its binary equivalent. For example, the binary equivalent of decimal 48 is 110000. This binary value indicates that bits B5 and B4 are set.

## Common commands

**NOTE** Each common command is preceded by an asterisk (\*).

Common commands are device commands that are common to all devices on the bus. These commands are designated and defined by the IEEE-488.2 standard. Common commands are listed in [Table 3-8](#).

Table 3-8  
**IEEE-488.2 common commands and queries**

Mnemonic	Name	Description
*CLS	Clear status	Clear the standard event register and error queue.
*ESE <NRf>	Event enable command	Program the standard event enable register.
*ESE?	Event enable query	Read the standard event enable register.
*ESR?	Event status register query	Read the standard event enable register and clear it.
*IDN?	Identification query	Returns the manufacturer, model number, serial number, and firmware revision levels of the unit.
*OPC	Operation complete command	Set the operation complete bit in the standard event register after all pending commands have been executed.
*OPC?	Operation complete query	Places an ASCII "1" into the output queue when all pending selected device operations have been completed.
*RST	Reset command	Returns the relay unit to the *RST default condition.
*SRE<NRf>	Service request enable command	Programs the service request enable register.
*SRE?	Service request enable query	Reads the service request enable register.
*STB?	Status byte query	Reads the status byte register.
*TST?	Self-test query	Performs a checksum test on ROM and returns the result.
*WAI	Wait-to-continue command	Wait until all previous commands are executed.

### \*CLS — Clear status

### Clear status registers and error queue

Use the \*CLS command to clear (set to 0) the bits of the following registers:

- Standard event register
- Error queue

**\*ESE <NRf> — Event Enable****Program the standard event enable register****\*ESE? —Event Enable Query****Read the standard event register**

Parameter	<NRf> = 0	Clear register
	1	Set OPC(B0)
	4	Set QYE (B2)
	8	Set DDE(B3)
	16	Set EXE(B4)
	32	Set CME(B5)
	64	Set URQ(B6)
	128	Set PON(B7)
	255	Set all bits

Use the \*ESE command to program the Standard Event Enable Register. This command is sent with the decimal equivalent of the binary value that determines the desired state (0 or 1) of the bits in the register. This register is cleared on power-up.

This register is used as a mask for the Standard Event Register. When a standard event is masked, the occurrence of that event will not set the Event Summary Bit (ESB) in the Status Byte Register. Conversely, when a standard event is unmasked (enabled), the occurrence of that event sets the ESB bit. For information on the Standard Event Register and descriptions of the standard event bits, see the \*ESR? command.

A cleared bit (0) in the enabled register prevents (masks) the ESB bit in the Status Byte Register from setting when the corresponding standard event occurs. A set bit (1) in the enable register allows (enables) the ESB bit to set when the corresponding standard event occurs.

The Standard Event Enable Register is shown in [Figure 3-8](#) and includes the decimal weight of each bit. The sum of the decimal weights of the bits that you wish to be set is the parameter value that is sent with the \*ESE command. For example, to set the CME and QYE bits of the Standard Event Enable Register, send the following command:

```
*ESE 36
```

```
Where:  CME (bit B5) = 32
        QYE (bit B2) =  4
        <NRf> = 36
```

If a command error (CME) occurs, bit B5 of the Standard Event Status Register sets. If a query error (QYE) occurs, bit B2 of the Standard Event Status Register sets. Since both of these events are unmasked (enabled) the occurrence of any one of them causes the ESB bit in the Status Byte Register to set. Read the Standard Event Status Register using the \*ESE? query command.

Figure 3-8

**Standard event enable register**

Bit Position	(B15 - B8)	B7	B6	B5	B4	B3	B2	B1	B0
Event	—	PON	—	CME	EXE	DDE	QYE	—	OPC
Decimal Weighting	—	128 (2 <sup>7</sup> )	—	32 (2 <sup>5</sup> )	16 (2 <sup>4</sup> )	8 (2 <sup>3</sup> )	4 (2 <sup>2</sup> )	—	1 (2 <sup>0</sup> )
Value	—	0/1	—	0/1	0/1	0/1	0/1	—	0/1

Value: 1 = Enable Standard Event  
0 = Disable (Mask) Standard Event

Events: PON = Power On  
CME = Command Error  
EXE = Execution Error  
DDE = Device-Dependent Error  
QYE = Query Error  
OPC = Operation Complete



**\*ESR? - Event Status Register Query** Reads then clears the standard event status register

Use this command to acquire the value (in decimal) of the Standard Event Register (see [Figure 3-9](#)). The binary equivalent of the returned decimal value determines which bits in the register are set. The register is cleared on power-up.

Figure 3-9  
**Standard event status register**

Bit Position	(B15 - B8)	B7	B6	B5	B4	B3	B2	B1	B0
Event	—	PON	—	CME	EXE	DDE	QYE	—	OPC
Decimal Weighting	—	128 (2 <sup>7</sup> )	—	32 (2 <sup>5</sup> )	16 (2 <sup>4</sup> )	8 (2 <sup>3</sup> )	4 (2 <sup>2</sup> )	—	1 (2 <sup>0</sup> )
Value	—	0/1	—	0/1	0/1	0/1	0/1	—	0/1

Value: 1 = Event Bit Set  
2 = Event Bit Cleared

Events: PON = Power On  
CME = Command Error  
EXE = Execution Error  
DDE = Device-Dependent Error  
QYE = Query Error  
OPC = Operation Complete

A set bit in this register indicates that a particular event has occurred. For example, for an acquired decimal value of 48, the binary equivalent is 00110000. From this binary value, bits B4 and B5 of the Standard Event Status Register are set. These bits indicate that a device-dependent error and command error have occurred.

The bits of the Standard Event Status Register are described as follows:

- **Bit B0, Operation Complete** — A set bit indicates that all pending selected device operations are completed and the S46 is ready to accept new commands. This bit only sets in response to the \*OPC command. It is not affected by the \*OPC? command.
- **Bit B1** — Not used.
- **Bit B2, Query Error (QYE)** — A set bit indicates that you attempted to read data from an empty Output Queue.
- **Bit B3, Device-Dependent Error (DDE)** — A set bit indicates that an instrument operation did not execute properly due to some internal condition.
- **Bit B4, Execution Error (EXE)** — A set bit indicates that the S46 detected an error while trying to execute a command.

- **Bit B5, Command Error (CME)** — A set bit indicates that a command error has occurred. Command errors include:
  - IEEE-488.2 syntax error — S46 received a message that does not follow the defined syntax of the IEEE-488.2 standard.
  - Semantic error — S46 received a command that was misspelled, or received an optional IEEE-488.2 command that is not implemented.
- **Bit B6** — Not used.
- **Bit B7, Power ON (PON)** — A set bit indicates that the S46 has been turned off and turned back on since the last time this register has been read.

### **\*IDN? — identification query**

**Reads identification code**

The identification code includes the manufacturer, model number, serial number, and firmware revision levels. Identification codes vary with the model number, output formats and output types. Power supplies set for the exponential output format and Keithley output types have the following codes:

KEITHLEY INSTRUMENTS INC., S46, xxxxxxx, yyyy

Where: xxxxxxx is the serial number.  
yyyy is the firmware revision level of the digital board ROM.

### **\*OPC — operation complete**

**Sets OPC bit**

### **\*OPC? — operation complete query**

**Places a “1” in output queue**

When \*OPC is sent, the OPC bit in the standard event register will set after all pending command operations are complete. When \*OPC? is sent, an ASCII “1” is placed in the output queue after all pending command operations are complete.

The following syntax rules explain how to use \*OPC and \*OPC? with other commands:

*NOTE Send \*OPC or \*OPC?, separated by a semicolon, on the same line as another query. If sent on separate lines, an error occurs. The \*OPC? can be sent on the same line with a command that is not a query, or on a separate line as a command (not a query).*

### **\*RST — reset**

**Return relay unit to \*RST defaults**

When the \*RST command is sent, the relay unit performs the following operations:

1. Returns the instrument to the RST default conditions (see “Default” column of SCPI tables) and opens all relay paths.
2. Cancels all pending commands.
3. Cancels response to any previously received \*OPC and \*OPC? commands.

**\*SRE <NRf> — Service Request Enable**      **Program register**  
**\*SRE? — Service Request Enable Query**      **Read register**

Parameter	<NRf> = 0	Clears enable register
	4	Set EAV bit (Bit 2)
	16	Set MAV bit (Bit 4)
	32	Set ESB (Bit 5)
	255	Set all bits

Use the \*SRE command to program the Service Request Enable Register. Send this command with the decimal equivalent of the binary value that determines the desired state (0 or 1) of each bit in the register. This register is cleared on power-up.

This enable register is used along with the Status Byte Register to generate service requests (SRQ). With a bit in the Service Request Enable Register set, an SRQ occurs when the corresponding bit in the Status Byte Register is set by an appropriate event. For more information on register structure, see the information presented earlier in this section.

The Service Request Enable Register is shown in [Figure 3-10](#). Notice that the decimal weight of each bit is included in the illustration. The sum of the decimal weights of the bits that you wish to set is the value that is sent with the \*SRE command. For example, to set the ESB and MAV bits of the Service Request Enable Register, send the following command:

Where:    ESB (bit B5) = 32  
           MAV (bit B4) = 16  
           <NRf> = 48

The contents of the Service Request Enable Register can be read using the \*SRE? query command.

*Figure 3-10*  
**Service request enable register**

Bit Position	B7	B6	B5	B4	B3	B2	B1	B0
Event	—	—	ESB	MAV	—	EAV	—	—
Decimal Weighting	—	—	32 (2 <sup>5</sup> )	16 (2 <sup>4</sup> )	—	4 (2 <sup>2</sup> )	—	—
Value	—	—	0/1	0/1	—	0/1	—	—

Value: 1 = Enable Service Request Event  
 0 = Disable (Mask) Service Request Event

Event: ESB = Event Summary Bit  
 MAV = Message Available Bit  
 EAV = Error Available  
 MSB = Measurement Summary Bit

**\*STB? - Status Byte Query****Read Status Byte Register**

Use the \*STB? query command to acquire the value (in decimal) of the Status Byte Register. The Status Byte Register is shown in Figure 3-11. The binary equivalent of the decimal value determines which bits in the register are set.

Figure 3-11  
**Status byte register**

Bit Position	B7	B6	B5	B4	B3	B2	B1	B0
Event	—	MSS RQS	ESB	MAV	—	EAV	—	—
Decimal Weighting	—	64 (2 <sup>6</sup> )	32 (2 <sup>5</sup> )	16 (2 <sup>4</sup> )	—	4 (2 <sup>2</sup> )	—	—
Value	—	0/1	0/1	0/1	—	0/1	—	—

Value: 1 = Event Bit Set  
0 = Event Bit Cleared

Events: MSS = Master Summary Status  
RQS = Request Service  
ESB = Event Summary Bit  
MAV = Message Available  
EAV = Error Available  
MSB = Measurement Available Bit

All bits, except Bit B6, in this register are set by other event registers and queues. Bit 6 sets when one or more enabled conditions occur.

The \*STB? query command does not clear the status byte register. This register can only be cleared by clearing the related registers and queues.

For example, for an acquired decimal value of 48, the binary equivalent is 00110000. This binary value indicates that bits 4 and 5 of the Status Byte Register are set.

The bits of the Status Byte Register are described as follows:

- **Bit 0** — Not used.
- **Bit 1** — Not used.
- **Bit 2, Error Available (EAV)** — A set bit indicates that an error or status message is present in the Error Queue. The message can be read using one of the following SCPI commands:
  - :SYSTem:ERRor?
  - :STATus:QUEue?

- **Bit 3** — Not used.
- **Bit 4, Message Available (MAV)** — A set bit indicates that a message is present in the Output Queue. The message is sent to the computer when the S46 is addressed to talk.
- **Bit 5, Event Summary Bit (ESB)** — A set bit indicates that an enabled standard event has occurred. The event can be identified by reading the Standard Event Status Register using the \*ESE? query command.
- **Bit 6, Master Summary Status (MSS)/Request Service (RQS)** — A set bit indicates that one or more enabled Status Byte conditions have occurred. Read the MSS bit by using the STB? query command, or perform a serial poll to detect the occurrence of a service request (RQS bit set).
- **Bit 7** — Not used.

**\*TST? — self-test query****Run self test and read result**

Use this query command to perform a self-test for the system.

When the unit is addressed to talk, the coded result is sent from the output queue to the computer. A returned value of one (1) indicates that the test passed, and a value of zero (0) indicates that the test failed.

**\*WAI — wait-to-continue****Wait until previous commands are completed**

Effectively, the \*WAI command is a no-op (no operation) for the relay unit and therefore, does not need to be used.

Two types of device commands exist:

**Sequential commands** — A command whose operations are allowed to finish before the next command is executed.

**Overlapped commands** — A command that allows the execution of subsequent commands while device operations of the overlapped command are still in progress.

The \*WAI command is used to suspend the execution of subsequent commands until the device operations of all previous overlapped commands are finished. The \*WAI command is not needed for sequential commands.

## Errors

Table 3-9 summarizes error and status messages that can be read with :SYST:ERR?

Table 3-9  
**Error and status message**

Number	Description	Event
-440	Query UNTERMINATED after indefinite response	EE
-430	Query DEADLOCKED	EE
-420	Query UNTERMINATED	EE
-410	Query INTERRUPTED	EE
-350	Queue overflow	SYS
-330	Self-test failed	EE
-260	Expression error	EE
-241	Hardware missing	EE
-224	Illegal parameter value	EE
-223	Too much data	EE
-222	Data out of range	EE
-221	Settings conflict	EE
-220	Parameter error	EE
-215	Arm deadlock	EE
-214	Trigger deadlock	EE
-213	Initialization ignored	EE
-212	Arm ignored	EE
-211	Trigger ignored	EE
-210	Trigger error	EE
-200	Execution error	EE
-171	Invalid expression	EE
-170	Expression error	EE
-161	Invalid block data	EE
-160	Block data error	EE
-158	String data not allowed	EE
-154	String too long	EE
-151	Invalid string data	EE
-150	String data error	EE
-148	Character data not allowed	EE
-144	Character data too long	EE
-141	Invalid character data	EE
-140	Character data error	EE

EE = error event

SE = status event

SYS = system error event

Table 3-9 (cont.)

**Error and status message**

Number	Description	Event
-128	Numeric data not allowed	EE
-124	Too many digits	EE
-123	Exponent too large	EE
-121	Invalid character in number	EE
-120	Numeric data error	EE
-113	Undefined header	EE
-112	Program mnemonic too long	EE
-111	Header separator error	EE
-110	Command header error	EE
-109	Missing parameter	EE
-108	Parameter not allowed	EE
-105	GET not allowed	EE
-104	Data type error	EE
-103	Invalid separator	EE
-102	Syntax error	EE
-101	Invalid character	EE
-100	Command error	EE
+000	No error	SE
+900	Internal System Error	EE

EE = error event

SE = status event

SYS = system error event





**4**

# Service Information

---

# Introduction

This section contains service information for the S46. The information is organized as follows:

- Handling and cleaning precautions
- Performance verification
- Replacing components

**WARNING** The information in this section is intended only for qualified service personnel. Some of the procedures may expose you to hazardous voltages that could result in personal injury or death. Do not perform these procedures unless you are qualified to do so.

## Handling and cleaning precautions

Because of the high-impedance areas on the S46, care should be taken when handling or servicing the switch to prevent possible contamination. The following precautions should be observed when servicing the S46.

### Handling precautions

Observe the following precautions when handling the S46:

- Do not touch connector insulators.
- Do not touch any board surfaces or components not associated with the repair.
- Do not touch areas adjacent to electrical contacts.
- When servicing the unit, wear clean cotton gloves.
- Do not store or operate the S46 in an environment where dust could settle on the circuit board.

## Circuit board and connector cleaning

- Use dry nitrogen gas to clean any dust off the circuit board and components.
- Clean the contaminated area with methanol, then blow dry the entire board with dry nitrogen gas.
- If the connector insulators should become contaminated, either by inadvertent touching, or from air-borne deposits, they can be cleaned with a cotton swab dipped in clean methanol.
- Before use, allow items cleaned to dry for several hours in a 50°C low-humidity environment. Use dry nitrogen to decrease drying time.

## Performance verification

The following paragraphs discuss performance verification procedures for the S46 including a channel resistance verification procedure.

**CAUTION** Contamination will degrade the performance of the S46. To avoid contamination, do not touch the connectors.

**NOTE** Failure of any performance verification test may indicate that the unit is contaminated. See “*Handling and cleaning precautions*” earlier in this section for information on cleaning the controller.

## Environmental conditions

All verification measurements should be made at an ambient temperature between 18° and 28°C, and at a relative humidity of less than 70%.

## Recommended equipment

Table 4-1 summarizes the equipment necessary for performance verification (channel resistance tests).

Table 4-1  
**Recommended verification equipment**

Manufacturer/Model	Equipment description	Specifications
Keithley 2010	Digital multimeter	10Ω range, 60ppm
—	Custom-made test lead set	See Figure 4-1.

Figure 4-1  
**Custom made test lead set**

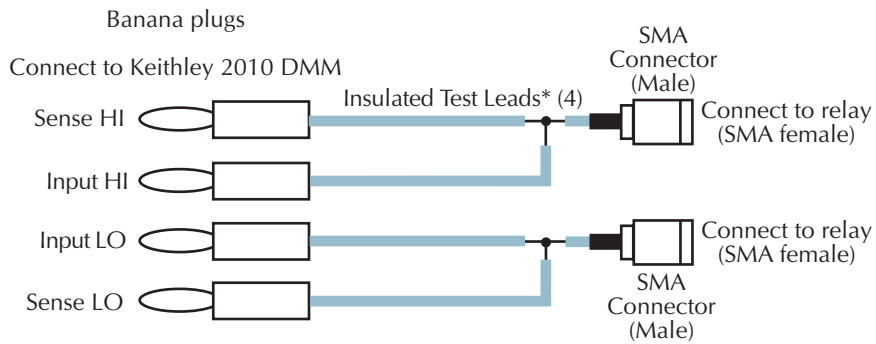

\* Test leads should be kept as short as possible.

Schematic:

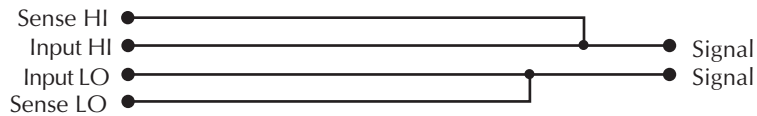

## Channel resistance tests

Perform the following steps to verify the relay contact is closing properly, the relay resistance is within specification, and that the relay opens properly.

1. Turn on the Model 2010 DMM and allow it to warm up for one hour before making measurements.
2. Set the Model 2010 to the  $10\Omega$  range and use the custom-made test lead set to make connections to the relay contact and common (Figure 4-2).
3. Close the relay.
4. Note the resistance reading on the Model 2010 and verify that it is  $<0.25\Omega$ .
5. Open the relay.
6. Note the resistance reading on the Model 2010 and verify that it indicates an open circuit.
7. Repeat the measurements for all relay contacts.

Figure 4-2

### Channel resistance test connections

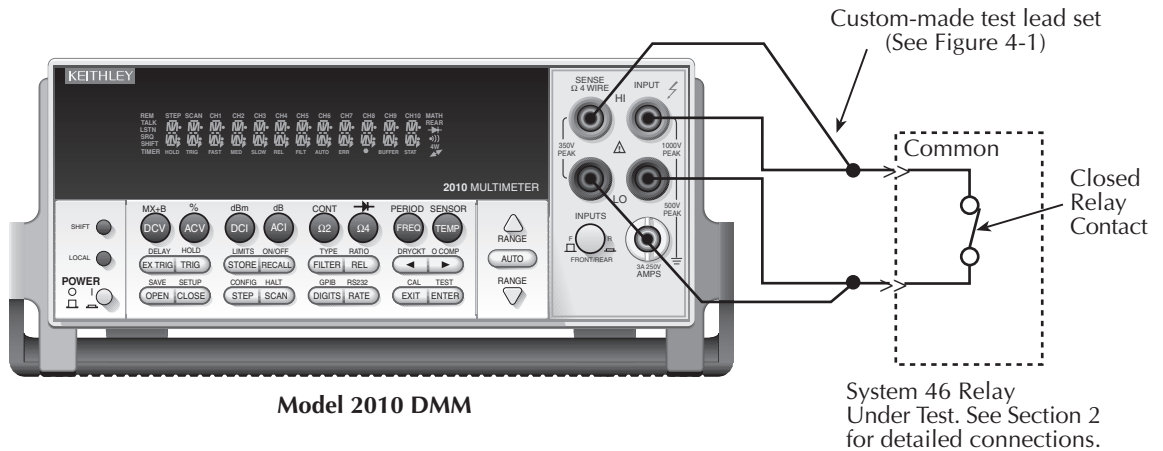

# Replacing components

## Replacing relays

Defective relays can be replaced without removing the top cover of the S46. [Table 4-2](#) lists the part numbers for the relays that can be ordered from Keithley.

*Table 4-2*

**Keithley part numbers for S46 relays**

Relay	Keithley Part Number
SPDT	RL-258
SP4T	RL-259-2
SP6T	RL-259-1

**WARNING** Before replacing a relay, turn off the power and disconnect the line cord from the unit. Remove any signal connections from all relays.

### SPDT relay replacement

Perform the following steps to replace an SPDT relay:

1. Remove the two screws that secure the relay to the SPDT bracket ([Figure 4-3](#)).
2. Pull the relay out of the unit to gain access to the two control wires connected to the relay.
3. Disconnect the two control wires ([Figure 4-4](#)). You can de-solder or cut the wires. Take care not to allow the wires to fall into the unit.
4. Solder the wires to the terminals of the new relay.
5. Secure the relay to the SPDT bracket using the two screws ([Figure 4-3](#)).

Figure 4-3  
**SPDT relay mounting**

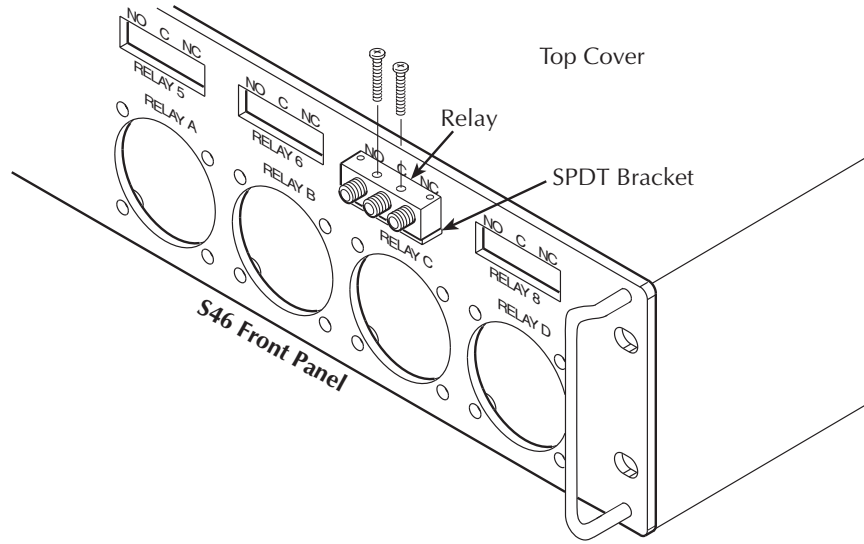
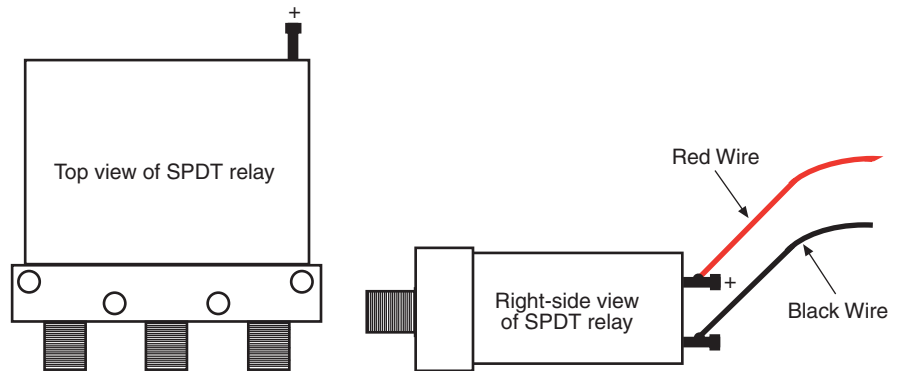

Figure 4-4  
**Connecting control wires to SPDT relay**



## SP4T or SP6T relay replacement

Perform the following steps to replace an SPDT relay:

1. Remove the four screws that secure the relay to the front panel (Figure 4-5).
2. Pull the relay out of the unit to gain access to the relay control cable connected to the relay. The control cable is terminated with a female DB-9 connector.
3. Loosen the captive screws on the DB-9 connector and disconnect the connector from the relay.
4. Connect the control cable to the new relay. Tighten the screws on the DB-9 connector.
5. Mount the relay to the front panel using the four screws (Figure 4-5).

Figure 4-5  
**SP4T and SP6T relay mounting**

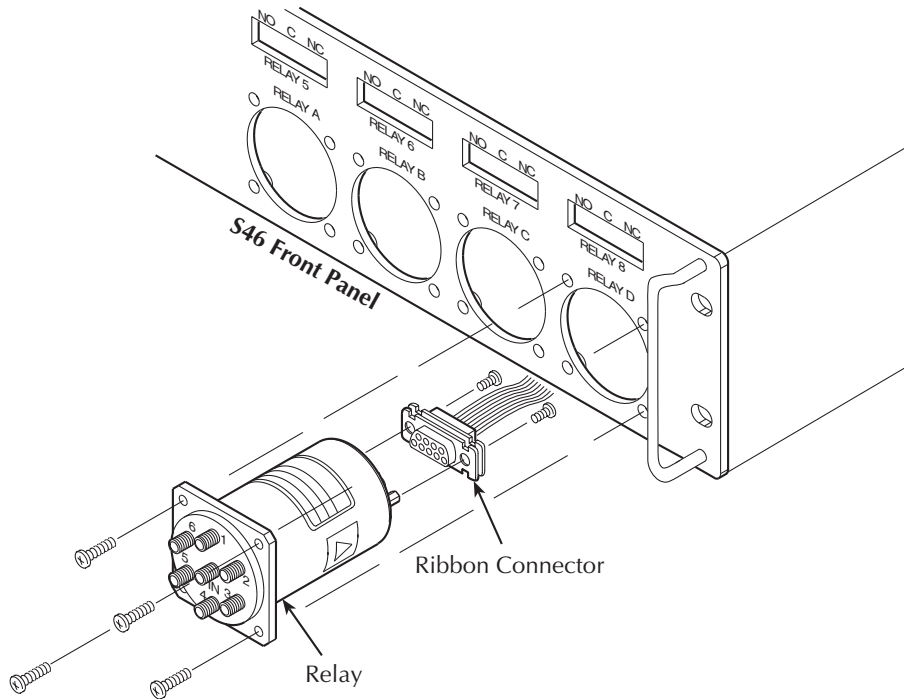



## Mainframe replacement parts

Replacement parts for the mainframe can be obtained directly from Keithley Instruments, Inc. See the parts list in [Section 5](#) for part numbers.

**WARNING** Use only the parts specified, in Section 5 of this manual, when servicing the equipment. Use of improper parts may expose the operator to hazardous voltages that could result in personal injury or death. Do not attempt to replace parts or otherwise service the equipment unless you are qualified to do so.

## Replacement precautions

**CAUTION** Observe the following precautions when replacing components:

- To avoid contamination which could degrade switch performance, always handle the switch only by the covers and side edges. Do not touch the connector, board surfaces, or components on the switch.
- Use care when removing components from the PC board to avoid pulling traces away from the circuit board. Before attempting to remove a relay, use an appropriate de-soldering tool to clear each mounting hole completely free of solder.

## Soldering considerations

When using solder on the circuit board, observe the following precautions:

- Use an OA-based (organic activated) flux, and take care not to spread the flux to other areas of the circuit board.
- Remove the flux from the work areas when the repair has been completed. Use pure water along with clean cotton swabs or a clean soft brush to remove the flux.
- Once the flux has been removed, swab only the repaired area with methanol, then blow dry the board with dry nitrogen gas.
- After cleaning, allow the card to dry in a 50°C low-humidity environment for several hours before use.

## Disassembly

Perform the following steps and refer to [Figure 4-6](#) to disassemble the S46 to gain access to and replace the relays or other components:

**WARNING** Before disassembly, disconnect all power sources and remove the unit from the instrument rack.

1. Disconnect all power sources and remove the S46 from the instrument rack.
2. Remove the screws that secure the top cover.

3. Remove the top cover.
4. Remove the screws that secure the digital board assembly to the chassis.
5. Remove the IEEE-488 connector nuts from the rear panel.
6. Remove the digital board from the chassis.
7. Remove the screws that secure the power supply to the chassis, then remove the power supply.

To assemble the S46, reverse the disassembly instructions. Make sure all parts are properly seated and secured, and that all connections are made properly.

Figure 4-6  
**S46 exploded view**

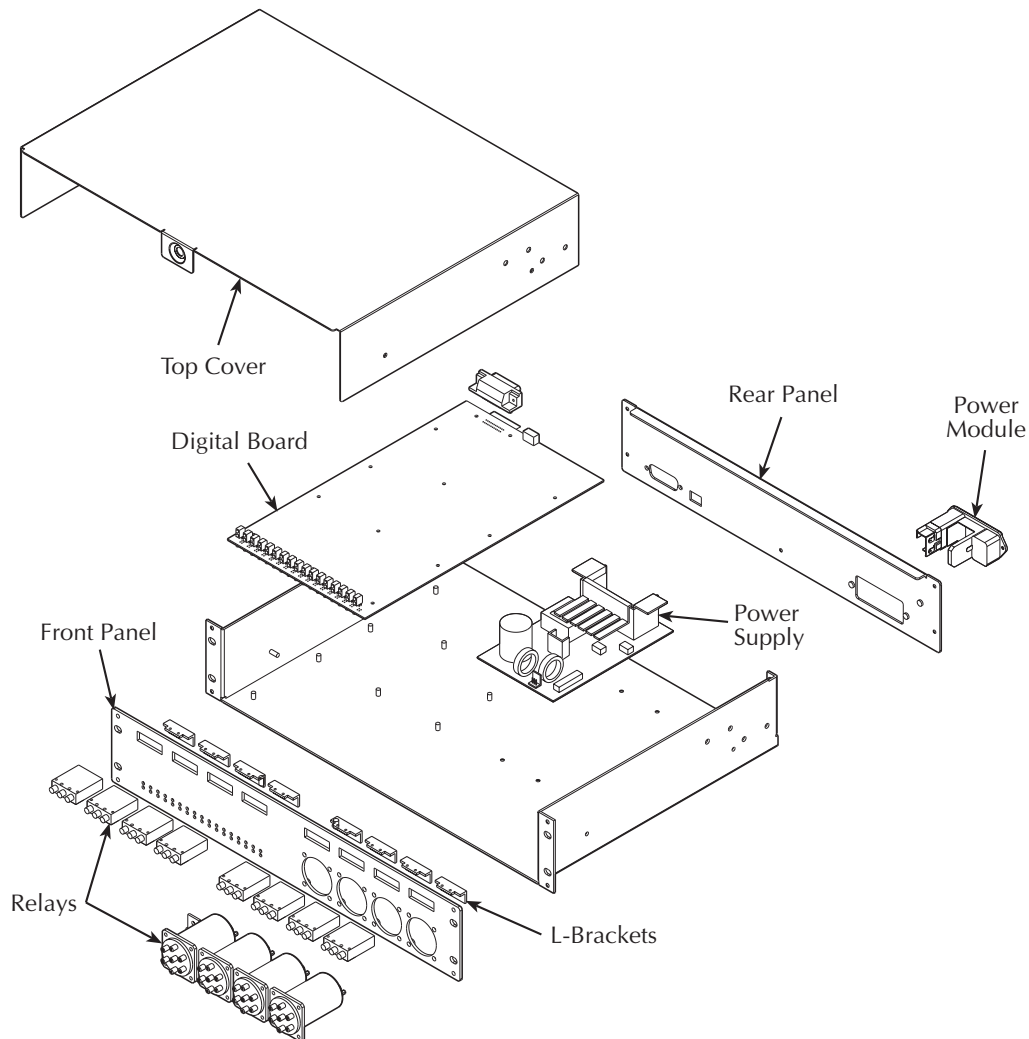

# 5

## Replaceable Parts

---

## Introduction

This section contains replacement parts information and component layout for the S46.

**WARNING** The information in this section is intended only for qualified service personnel. Do not attempt to replace parts or otherwise service the equipment unless you are qualified to do so.

## Parts list

Parts lists for the S46 are contained in [Table 5-1](#) and [Table 5-2](#).

## Ordering information

To place an order, or to obtain information concerning replacement parts, contact your Keithley representative or the factory (see inside front cover for addresses). When ordering parts, be sure to include the following information:

- Switch controller model number (S46).
- Serial number.
- Part description.
- Component designation (if applicable).
- Keithley part number.

## Factory service

If the switch is to be returned to Keithley Instruments for repair, perform the following:

- Call the Repair Department at 1-800-552-1115 for a Return Material Authorization (RMA) number.
- Complete the service form at the back of this manual, and include it with the instrument.
- Carefully pack the instrument in the original packing carton.
- Write ATTENTION REPAIR DEPARTMENT and the RMA number on the shipping label.

## Component layout

The following component layout drawing is provided on the following page:

- Component layout drawing: S46-100.



**WARNING** Use only the parts specified when servicing the equipment. Use of improper parts may expose the operator to hazardous voltages that could result in personal injury or death. Do not attempt to replace parts or otherwise service the equipment unless you are qualified to do so.

Table 5-1  
**S46 digital board parts list**

Circuit Designation	Description	Keithley Part No.
C1	CAP, 10UF, 20%, 25V, TANTALUM	C-440-10
C12,C15	CAP, 15P, 1%, 100V, CERAMIC	C-512-15P
C13	CAP, 47PF, 10%, 100V, CERAMIC	C-451-47P
C16	CAP, 100UF, 20%, 63V, ALUM ELEC	C-403-100
C2, C4, C8, C10, C14, C21, C24	CAP, .01UF, 10%, 50V, CERAMIC	C-491-.01
C20	CAP, 150U, 20%, 50V, ALUM ELEC	C-617-150
C29	CAP, 470U, 20%, 25V, ALUM ELEC	C-478-470
C3, C5-C7, C9, C11, C17-C19, C22, C23, C25-C28	CAP, .1UF, 10%, 25V, CERAMIC	C-495-.1
C31-C36, C39-C42, C45-C51	CAP, .1UF, 10%, 25V, CERAMIC	C-495-.1
C37, C38, C43, C44	CAP, 47P, 5%, 100V, CERAMIC	C-465-47P
CR1	SCHOTTKY POWER RECTIFIER	RF-151
DS17	BI-LEVEL LED, 90 DEG, BLU/RED	PL-116-2
DS1-DS16	BI-LEVEL LED, 90 DEG, GRN/GRN	PL-116-1
J18, J19, J20, J21, J22, J23, J24, J25	LATCHING HEADER, FRICTON, SGL ROW	CS-724-3
J3	CONN, RIGHT ANGLE, 24 PIN	CS-501
J31	CONN, MALE, 2 PIN	CS-288-2
J5, J6, J7, J8	CONN, HEADER STRAIGHT SOLDER PIN	CS-368-10
L1	FERRITE CHIP, 600 OHM, BLM32A07	CH-62
L3	CHOKE	CH-87-2
L4	CHOKE, 1.2A	CH-94-1
Q1, Q2, Q3, Q4, Q5, Q6, Q7, Q8	TRANS, N-MOSFET, VN0605T	TG-243
R13	RES, 806, 1%, 100MW, THICK FILM	R-418-806
R14, R31-R33, R38, R39, R46, R47	RES, 1K, 1%, 100MW, THICK FILM	R-418-1K
R1-R3, R7, R11, R15, R28	RES, ARRAY 4X10K, 5%, .125W	TF-276-10K
R20	RES, 499, 1%, 100MW, THICK FILM	R-418-499
R21, R22	RES, 2K, 1%, 100MW, THICK FILM	R-418-2K

Table 5-1 (cont.)

**S46 digital board parts list**

Circuit Designation	Description	Keithley Part No.
R23, R25	RES, 4.75K, 1%, 100MW, THICK FILM	R-418-4.75K
R26	RES, 10M, 1%, 125MW, THICK FILM	R-418-10M
R27	RES, 332K, 1%, 100MW, THICK FILM	R-418-332K
R30, R41	RES, 49.9, 1%, 100MW, THICK FILM	R-418-49.9
R35	RES, .0499, 1%, 100MW, THICK FILM	R-418-.0499
R4, R5, R8-R10, R12, R16-R19, R24, R29, R34, R36	RES, 10K, 1%, 100MW, THICK FILM	R-418-10K
R40, R52-R55	RES, 10K, 1%, 100MW, THICK FILM	R-418-10K
R42-R45, R48-R51	RES, 150K, 1%, 100MW, THICK FILM	R-418-150K
R6	RES, ARRAY 4X1K 5%, .125W	TF-276-1K
S1	SWITCH, SLIDE DIP	SW-449-5
SO12	SOCKET PLCC-032-T-A	SO-143-32
TP1, TP2, TP3, TP4, TP5, TP6	SURFACE MOUNT PCB TEST POINT	CS-1026
U1	IC, MICROCONTROLLER MC68332-FC	LSI-161
U10	IC, OCTAL INTER BUS TRANS, 75161	IC-647
U11	IC, CMOS STATIC RAM	LSI-162-70
U12	PROGRAMMED ROM	S46-800*
U14-U16, U18, U21-U24	IC, QUAD LOW SIDE DRIVER	IC-1351
U2, U3, U6, U17	IC, HEX SCHMITT INVERT TRIGGER	IC-1397
U25	IC, 3A VOLTAGE REGULATOR, STEP DOWN	IC-1455
U27	IC, OCTAL D FLIP FLOP	IC-1061
U4	64K BIT SERIAL FRAM	IC-1381
U5	IC, UNDERVOLTAGE SENSE CIRCUIT	IC-1067
U7, U13, U19, U20	IC, 8 STAGE SHIFT, C074HC409AM	IC-1026
U8	IC, GPIB ADAPTER, 9914A	LSI-123
U9	IC, OCTAL INTERFACE BUS, 75160	IC-646
Y1	CRYSTAL, FSM327	CR-41

\* Order current firmware revision (for example, S46-800A01).

**WARNING** Use only the parts specified when servicing the equipment. Use of improper parts may expose the operator to hazardous voltages that could result in personal injury or death. Do not attempt to replace parts or otherwise service the equipment unless you are qualified to do so.

Table 5-2  
**S46 mechanical parts list**

Qty.	Description	Keithley Part No.
2	CONNECTOR	CS-236
1	CONNECTOR, HOUSING	CS-638-3
1	CONNECTOR	CS-275
6	CONNECTOR	CS-276
1	CONN, FEMALE, 3 PIN, SHAPELESS	CS-287-3
1	HOUSING, CONNECTOR 6 PIN	CS-287-6
1	CONNECTOR, HARDWARE KIT	CS-713
1	FUSE HOLDER	FH-39
1	FUSE	FU-106-1.6
2	HANDLE	HH-30-7
1	AC ON/OFF LINE SWITCH	PM-6-1
1	65 WATT 28V POWER SUPPLY	PS-81-1A
1	CHASSIS	SYS46-301A
1	REAR PANEL	SYS46-303A
1	FRONT PANEL	SYS46-305A
1	COVER	SYS46-307A



# A Specifications

---

# S46 Microwave Switch System

## S46 Microwave Switch System Specifications

### Maximum Configuration

- (8) – SPDT relays
- (4) – Multi-pole relays (SP3T, SP4T, SP5T, SP6T)

### Relay Specifications

**CONNECTOR TYPE:** Female SMA connector.

**CONTACT LIFE:** 2 million cycles minimum.

**VSWR:**

- DC–6GHz: 1.25:1 max.
- DC–12GHz: 1.40:1 max.
- DC–18GHz: 1.50:1 max.

**INSERTION LOSS:**

- DC–6GHz: 0.2dB max.
- DC–12GHz: 0.4dB max.
- DC–18GHz: 0.5dB max.

**ISOLATION:**

- DC–6GHz: 70dB max.
- DC–12GHz: 60dB max.
- DC–18GHz: 60dB max.

**ACTUATION TIME:** SPDT: 20ms max. **Multi-pole:** 15ms max.

**MAXIMUM SIGNAL:** 42V peak, any terminal to earth.

**FREQUENCY RANGE:** 0–18GHz.

### GENERAL

**CONTACT CLOSURE COUNTERS:** 1 counter per channel, up to 10 million counts each, maintained in non-volatile memory.

**NON-VOLATILE STORAGE:** 32 separate locations; each location up to 68 bytes long, for user-definable channel and system parameters.

**NUMBER OF RELAY CONTROL LINES:** 32, each open collector driver capable of 300mA sink current (max.).

**INTERFACE:** GPIB (IEEE 488.2) and SCPI.

**INDICATORS:** Power, relay position status and error LED.

**POWER:** 100–240VAC, 50 or 60Hz.

**POWER CONSUMPTION:** 80VA max.

**WARRANTY:** 1 year.

**ENVIRONMENT:** **Operating:** 0° to 40°C. up to 35°C < 80% RH.  
**Storage:** –25° to 65°C.

**EMC:** Conforms to European Union Directive 89/336/EEC.

**SAFETY:** Conforms with European Union Directive 73/23/EEC.

**DIMENSIONS:** 89mm high × 485mm wide × 370mm deep  
(3.5" × 19" × 14.563").

**SHIPPING WEIGHT:** 13kg (28 lbs).

**ACCESSORIES SUPPLIED:** Power cord, instruction manual, and rack mount kit.

---

# Index

## Numerics

16-bit status register 3-23

## A

Available accessories 1-4

## B

Bus connections 3-2

## C

Card cleaning 4-3  
Channel resistance tests 4-5  
Circuit board removal 4-10  
Clearing registers and queues 3-22  
Command diagram 3-5  
Command execution rules 3-6  
Command messages 3-4  
Commands and parameters 3-3  
Common commands 3-24  
    \*CLS 3-24  
    \*ESE 3-25  
    \*ESE? 3-25  
    \*ESR? 3-27  
    \*IDN? 3-28  
    \*OPC 3-28  
    \*OPC? 3-28  
    \*RST 3-28  
    \*SRE 3-29  
    \*SRE? 3-29  
    \*STB? 3-30  
    \*TST? 3-31  
    \*WAI 3-31  
Component layout 5-2  
Configuration 2-2  
Connections 1-5, 2-1  
    introduction 2-2  
    RS-232 2-5  
    Signal 2-4  
Connector integrity 2-11  
Controlling relay connections 3-6

## E

Enable registers 3-18  
Environmental conditions 4-3  
Error and status message 3-32  
Error queue 3-18

Event register sets 3-17  
Example command 3-5  
Exploded view 4-10

## F

Factory service 5-2  
Flux 4-9  
Foot mounting 1-6

## G

General Information 1-1  
General information 1-2  
GPIB commands 3-8  
GPIB control connection 2-6  
GPIB primary address 2-8  
Ground connection 2-10

## H

Handling 4-2  
Handling precautions 2-2, 4-2

## I

Insertion loss 2-12  
Inspection for damage 1-3  
Installation 1-5  
    Rack mounting 1-5  
        Rack mount kit 1-5  
        Rack mount procedure 1-6  
Instruction manual 1-4  
Introduction 1-2, 4-2, 5-2

## L

Layout 2-2

## M

Manual addenda 1-2  
Maximum signal considerations 3-2  
Message exchange protocol 3-7  
Multiple response messages 3-7

## O

Opening or closing the relay 3-32  
Operation 3-1  
    Introduction 3-2  
    RS-232 3-2  
Ordering information 5-2  
Output queue 3-18  
Overview 1-2

---

## P

- Parameter types 3-4
- Parts list 5-2
- Path isolation 2-11
- Performance verification 4-3
- Power connections 2-8
  - Line fuse replacement 2-8
  - Line power connection 2-8
  - Line voltage 2-8
  - Power supply fuse replacement 2-9
- Primary address 3-3
- Program message terminator (PMT) 3-5
- Programming enable registers 3-23
- Programming syntax 3-3

## Q

- Query Commands 3-4
- Queues 3-18

## R

- Rack preparation 1-6
- Reading registers 3-23
- Recommended verification equipment 4-4
- Relay kits 1-4
- Relay replacement 4-9
- Repacking 1-4
- Repair department phone number 5-2
- Replaceable Parts 5-1
- Replacement parts 4-9
- Replacement precautions 4-9
- Replacement relays 1-5
- Replacing components 4-6
- Response message terminator (RMT) 3-7
- Response messages 3-7
- RFI/EMI 2-12
- ROUTe commands 3-8
  - :CLOSe 3-8
  - :CLOSe? 3-8
  - :CONFigure:SPARAmeterN 3-10
  - :CONfigure:CPOLe 3-10
  - :COUNt? 3-9
  - :OPEN 3-9
  - :OPEN:ALL 3-10
  - :RCOunt 3-9
- RS-232 connector terminals 2-7

## S

- S46 digital board parts list 5-4
- S46 mechanical parts list 5-6
- Safety symbols and terms 1-3

- Schematic 2-4
- Sending a response message 3-7
- Serial polling and SRQ 3-21
- Service Information 4-1
- Service request enable register 3-21
- Shipment contents 1-3
- Short-form commands 3-4
- Signal connections 2-4
  - Channel assignments 2-5
  - Input/output connections 2-5
  - Relay configuration 2-5
- Signal considerations 3-2
- SMA cables and torque wrench 1-4
- Soldering considerations 4-9
- SP4T or SP6T relay replacement 4-8
- SPDT relay replacement 4-6
- Specifications A-1
- Status byte and SRQ 3-20
- Status Byte Register 3-20
- STATus commands 3-11
  - :CLEAr 3-13
  - :DISAbLe 3-13
  - :DISAbLe? 3-13
  - :ENABLe 3-12
  - :ENABLe? 3-12
  - [:NEXT]? 3-12
  - :PRESet 3-11
  - :QUEue 3-11
- Status model 3-8
- Switching considerations 2-11, 3-32
- Symbols and terms 1-3
- SYSTEM commands 3-14
  - :CLEAr 3-15
  - :ERRor? 3-14
  - :SNUMber 3-15
  - :VERsion? 3-14

## U

- Unpacking and inspection 1-3

## V

- Voltage Standing Wave Ratio 2-11

## W

- Warranty 1-2

---

# Service Form

Model No. \_\_\_\_\_ Serial No. \_\_\_\_\_ Date \_\_\_\_\_

Name and Telephone No. \_\_\_\_\_

Company \_\_\_\_\_

List all control settings, describe problem and check boxes that apply to problem. \_\_\_\_\_

\_\_\_\_\_

Intermittent                       Analog output follows display                       Particular range or function bad; specify \_\_\_\_\_

IEEE failure                       Obvious problem on power-up                       Batteries and fuses are OK

Front panel operational     All ranges or functions are bad                       Checked all cables

Display or output (check one)

Drifts                                       Unable to zero                                       Unstable

Overload                                       Will not read applied input

Calibration only                       Certificate of calibration required                       Data required

(attach any additional sheets as necessary)

Show a block diagram of your measurement including all instruments connected (whether power is turned on or not). Also, describe signal source.

Where is the measurement being performed? (factory, controlled laboratory, out-of-doors, etc.) \_\_\_\_\_

\_\_\_\_\_

What power line voltage is used? \_\_\_\_\_ Ambient temperature? \_\_\_\_\_ °F

Relative humidity? \_\_\_\_\_ Other? \_\_\_\_\_

Any additional information. (If special modifications have been made by the user, please describe.)

\_\_\_\_\_

Be sure to include your name and phone number on this service form.





Specifications are subject to change without notice.

All Keithley trademarks and trade names are the property of Keithley Instruments, Inc.

All other trademarks and trade names are the property of their respective companies.

**KEITHLEY**

**Keithley Instruments, Inc.** 28775 Aurora Road • Cleveland, Ohio 44139 • 440-248-0400 • Fax: 440-248-6168  
**1-888-KEITHLEY (534-8453) • [www.keithley.com](http://www.keithley.com)**

**Sales Offices:**

<b>BELGIUM:</b>	Bergensesteenweg 709 • B-1600 Sint-Pieters-Leeuw • 02-363 00 40 • Fax: 02-363 00 64
<b>CHINA:</b>	Yuan Chen Xin Building, Room 705 • 12 Yumin Road, Dewai, Madian • Beijing 100029 • 8610-82251886 • Fax: 8610-82251892
<b>FINLAND:</b>	Halsuantie 2 • 00420 Helsinki, Finland • 09-53 06 65 60 • Fax: 09-53 06 65 65
<b>FRANCE:</b>	3, allée des Garays • 91127 Palaiseau Cédex • 01-64 53 20 20 • Fax: 01-60 11 77 26
<b>GERMANY:</b>	Landsberger Strasse 65 • 82110 Germering • 089-84 93 07-40 • Fax: 089-84 93 07-34
<b>GREAT BRITAIN:</b>	Unit 2 Commerce Park, Brunel Road • Theale, Berkshire RG7 4AB • 0118 -929 75 00 • Fax: 0118- 929 75 19
<b>INDIA:</b>	1/5, Eagles Street • Langford Town • Bangalore 560 025 • 080 212 80-27 • Fax: 080 212 80 05
<b>ITALY:</b>	Viale San Gimignano, 38 • 20146 Milano • 02-48 39 16 01 • Fax: 02-48 30 22 74
<b>JAPAN:</b>	New Pier Takeshiba North Tower 13F • 11-1, Kaigan 1-chome • Minato-ku, Tokyo 105-0022 • 81-3-5733-7555 • Fax: 81-3-5733-7556
<b>KOREA:</b>	2FL., URI Building • 2-14 Yangjae-Dong • Seocho-Gu, Seoul 137-888 • 82-2-574-7778 • Fax: 82-2-574-7838
<b>NETHERLANDS:</b>	Postbus 559 • 4200 AN Gorinchem • 0183-63 53 33 • Fax: 0183-63 08 21
<b>SWEDEN:</b>	c/o Regus Business Centre • Frosundaviks Allé 15, 4tr • 16970 Solna • 08-50 90 46 00 • Fax: 08-655 26 10
<b>TAIWAN:</b>	13F-3, NO. 6, Lane 99, Pu-Ding Road, Hsinchu, Taiwan, ROC. • 886-3-572-9077 • Fax: 886-3-572-9031

© Copyright 2003 Keithley Instruments, Inc.

Printed in the U.S.A.

5/03